



VACUUM SEALER SU-6100

Double chamber vacuum packing machine. 100m³/h.



FOOD PRESERVATION AND SOUS-VIDE
VACUUM PACKING MACHINES - "SENSOR ULTRA" LINE



SALES DESCRIPTION

High performance model with tilting cover, double chamber and 4 x 662 mm. sealing bars.
100 m³/h Busch vacuum pump.
Vacuum controlled by sensor.

- ✓ Powered by Busch.
- ✓ Vacuum controlled by sensor.
- ✓ Vacuum PLUS.
- ✓ LCD colour screen: all information at a glance.
- ✓ Backlit touch keyboard.
- ✓ Programmable: 25-programme memory. Blocking option.
- ✓ "Pause" button.
- ✓ Phased vacuum programme.
- ✓ Detection of the evaporation of liquids.
- ✓ Double seal.
- ✓ Cordless sealing bar.
- ✓ Progressive decompression.
- ✓ Vac-Norm ready with Automatic decompression.
- ✓ Stainless steel body and chambers.
- ✓ Tilting cover made of thick, robust stainless steel.
- ✓ Dry-oil programme for drying the pump.
- ✓ Working hours counter for oil changes.
- ✓ Safety system with protection against vacuum failure.

INCLUDES

- ✓ BUSCH pump.
- ✓ Sensor Controls.
- ✓ 25 programmable settings.
- ✓ Vacuum PLUS: up to 10 seconds of extra vacuum pull.
- ✓ Soft air function.
- ✓ "PAUSE" function.
- ✓ Liquid detection system.
- ✓ Dry oil cycle.
- ✓ NSF Approved.
- ✓ 4 filling plates.

OPTIONAL

- Inert gas.
- Printer.
- Bluetooth connectivity.
- Vacuum packing bags.
- External vacuum kit for Vac-Norm, containers and accessories.
- Bag cutting kit.
- Support for liquid packaging.
- Additional filling plates.

ACCESSORIES

- Bag cutting kits
- Filling plates
- Liquid insert plates
- Vac-norm external vacuum kits
- Vac-norm containers
- Smooth bags for vacuum packing
- Thermal labels for CG2 / RB printer
- RB Desktop printer for SU vacuum packing machines
- Thermal transfer labels for RB printer

SPECIFICATIONS

Pump capacity: 100 m³/h
Pump capacity (60 Hz): 120 m³/h
Bar length: 662 mm + 662 mm
Total loading: 2200 W
Vacuum pressure (maximum): 0.5 mbar

Plug: --
Electrical connection: --

Internal dimensions

- ✓ Width: 662 mm
- ✓ Depth: 656 mm
- ✓ Height: 205 mm

External dimensions (WxDxH)

- ✓ Width: 1640 mm
- ✓ Depth: 874 mm
- ✓ Height: 1370 mm

Net weight: 360 Kg

Noise level (1m.): 75 dB(A)
Background noise: 32 dB(A)

Crated dimensions

980 x 1720 x 1280 mm
Gross weight: 435 Kg





VACUUM SEALER SU-6100

Double chamber vacuum packing machine. 100m³/h.



AVAILABLE MODELS

- 1141030 Vacuum packing machine SU-6100 400/50-60/3N
- 1141031 Vacuum packing machine SU-6100 400/50-60/3N -C-
- 1141032 Vacuum packing machine SU-6100G 400/50-60/3N
- 1141033 Vacuum packing machine SU-6100P 400/50-60/3N
- 1141034 Vacuum packing machine SU-6100+ 400/50-60/3N
- 1141035 Vacuum packing machine SU-6100P+ 400/50-60/3N
- 1141036 Vacuum packing machine SU-6100GP 400/50-60/3N
- 1141037 Vacuum packing machine SU-6100G+ 400/50-60/3N
- 1141038 Vacuum packing machine SU-6100GP+ 400/50-60/3N
- 1141040 Vacuum packing machine SU-6100 220/60/3
- 1141041 Vacuum packing machine SU-6100 220/60/3 -C-
- 1141042 Vacuum packing machine SU-6100G 220/60/3
- 1141043 Vacuum packing machine SU-6100P 220/60/3
- 1141044 Vacuum packing machine SU-6100+ 220/60/3
- 1141045 Vacuum packing machine SU-6100P+ 220/60/3
- 1141046 Vacuum packing machine SU-6100GP 220/60/3
- 1141047 Vacuum packing machine SU-6100G+ 220/60/3
- 1141048 Vacuum packing machine SU-6100GP+ 220/60/3
- 1141072 Vacuum packing machine SU-6100GP+ 208-240/60/3
- 1141069 Vacuum packing machine SU-6100P 208-240/60/3 USA

* Ask for special versions availability

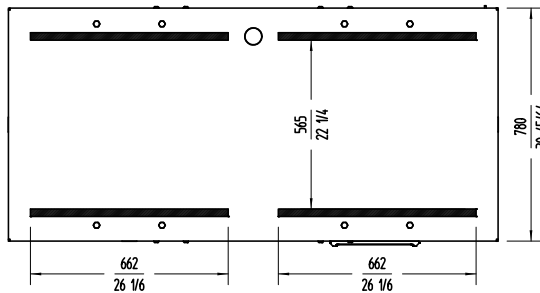
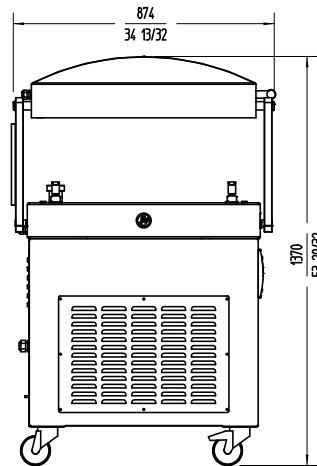
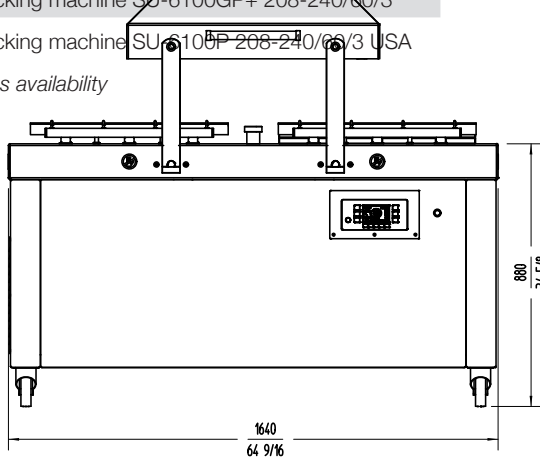

FOOD PRESERVATION AND SOUS-VIDE
VACUUM PACKING MACHINES - "SENSOR ULTRA" LINE

sammic | www.sammic.com
Food Service Equipment Manufacturer

Polígono Basarte, 1. phone +34 943 15 72 36
 20720 Azkoitia, Spain sales@sammic.com

Project	Date
Item	Qty
Approved	