

» SF600D _ SF600VD

Sfogliatrici da pavimento _ Floor dough sheeters _ Laminoirs à poser au sol
Laminadoras de masa para el suelo _ Тестораскаточные Машины Напольные

Macchine adatte a laboratori di pasticceria, panifici, ristoranti, gastronomie e pizzerie.

CARATTERISTICHE:

- larghezza tappeto 600 mm
- lunghezza piani 850, 1000, 1200, 1400 e 1600 mm
- pannello comandi elettromeccanico
- n. 2 mattarelli in dotazione
- abbassamento cilindri di laminazione: manuale
- visualizzazione digitale dello spessore di laminazione
- regolazione precisa dello spessore
- raschiatori facilmente amovibili
- velocità dei tappeti fissa (SF600D) o variabile (SF600VD)
- piani rialzabili per limitare al massimo l'ingombro quando la macchina non è in uso (esclusa su SF600DX1600 e SF600VDX1600)
- inversione del senso di laminazione tramite leva e pedale
- struttura in acciaio verniciato a polveri epossidiche (in acciaio inox su richiesta)

OPTIONAL:

- sfarinatore automatico
- mattarello aggiuntivo

Ideal machines for pastry shop, bakeries, restaurants, delicatessens and pizzerias.

FEATURES:

- conveyor belt width 600 mm
- table length 850, 1000, 1200, 1400 or 1600 mm
- electromechanical control panel
- n. 2 rolling pins dough included
- roller gap reduction: manual
- digital display for lamination thickness
- precise thickness regulation
- fixed speed of conveyor belts (SF600D) or variable (SF600VD)
- raised tables to limit the overall dimensions when the machine is not in use (excluded SF600DX1600 and SF600VDX1600)
- reverse laminating direction by handle and pedal
- body in epoxy painted steel (on request in stainless steel)
- easily removable scrapers

OPTIONAL:

- automatic flour duster
- rolling pin (additional)

Machines indiquées pour les laboratoires des pâtisseries et des boulangeries, les restaurants, les traiteurs et les pizzerias

CARACTÉRISTIQUES:

- largeur tapis 600 mm
- longueur plans 850, 1000, 1200, 1400 ou 1600 mm
- tableau de commande électromécanique
- 2 rouleaux à pâtisserie fournis
- abaissement des cylindres de laminage: manuel
- affichage numérique de l'épaisseur du laminage
- réglage précis de l'épaisseur
- racloirs facilement amovibles
- vitesse des tapis fixe (SF600D) ou variable (SF600VD)
- plans rehaussables pour limiter au maximum le gabarit lorsque la machine n'est pas utilisée (sauf sur les modèles SF600DX1600 et SF600VDX1600)
- inversion du sens de laminage au moyen d'un levier et d'une pédale
- structure en acier peint à la poudre époxy (en acier inox sur demande)

EN OPTION:

- saupoudroir à farine automatique
- rouleau à pâtisserie (supplémentaire)



SF600D _ 850 - 1000 - 1200 - 1400

Máquinas indicadas para pastelerías, panaderías, restaurantes, cafeterías y pizzerías.

CARACTERÍSTICAS:

- anchura bandas 600 mm
- longitud pisos 850, 1000, 1200, 1400 o 1600 mm
- panel de mandos electromecánico
- 2 rodillos
- descenso cilindros de laminación: manual
- visualización digital de espesor de laminación
- regulación precisa del espesor
- rascadores fáciles de extraer
- velocidad de las bandas fija (SF600D) o variable (SF600VD)
- pisos elevables para limitar al máximo las dimensiones cuando la máquina no está en uso (excluida en SF600DX1600 y SF600VDX1600)
- inversión del sentido de laminación a través de la palanca y pedal
- estructura de acero pintada con polvos epoxídicos (de acero inoxidable bajo pedido)

OPCIONAL:

- harinador automático
- rodillo (adicional)

Тестораскаточные машины идеальны для кондитерских, пекарен, ресторанов, кулинарий, пиццерий.

ОПИСАНИЕ:

- ширина транспортера - 600 мм
- длина одного транспортера 850, 1000, 1200, 1400, 1600 мм
- электромеханическая панель управления
- две скалки входят в стандартную комплектацию
- уменьшение зазора раскатывающих цилиндров вручную
- цифровой дисплей с индикацией толщины раскатки
- точная регулировка толщины
- скорость конвейерных лент фиксированная (SF600D) или регулируемая при помощи вариатора (SF600VD)
- транспортеры поднимаются во время простоев за исключением SF600DX1600 и SF600VDX1600
- реверс конвейерных лент при помощи рычага и педали
- корпус из окрашенной стали (по запросу из нержавеющей стали)
- скребки, которые легко обслуживать (вынимаются при помощи фронтального рычага)

ОПЦИИ:

- автоматическая подсыпка мукой
- дополнительная скалка



» SF600D _ SF600VD

Sfogliatrici da pavimento _ Floor dough sheeters _ Laminoirs à poser au sol
Laminadoras de masa para el suelo _ Тестораскаточные Машины Напольные

SF600VD
Pannello comandi con velocità variabile
Control panel with variable speed



Codice macchina Machine code		SF600DX850	SF600DX1000	SF600DX1200	SF600DX1400	SF600DX1600	SF600VDX850	SF600VDX1000	SF600VDX1200	SF600VDX1400	SF600VDX1600
Larghezza tappeto Conveyor belt width	mm	600	600	600	600	600	600	600	600	600	600
Lunghezza piano Table length	mm	850	1000	1200	1400	1600	850	1000	1200	1400	1600
Velocità tappeto in uscita Speed of discharge conveyor belt	mt./min.	36	36	36	36	36	3,5 / 43	3,5 / 43	3,5 / 43	3,5 / 43	3,5 / 43
Velocità tappeto in entrata Speed of infeed conveyor belt	mt./min.	21	21	21	21	21	2 / 25	2 / 25	2 / 25	2 / 25	2 / 25
Diametro rulli di laminazione Diameter of laminating rollers	mm	70	70	70	70	70	70	70	70	70	70
Apertura rulli di laminazione Roller gap	mm	0,2 - 37	0,2 - 37	0,2 - 37	0,2 - 37	0,2 - 37	0,2 - 37	0,2 - 37	0,2 - 37	0,2 - 37	0,2 - 37
Potenza motore Motor power	kW	0,75	0,75	0,75	0,75	0,75	0,75	0,75	0,75	0,75	0,75
Voltaggio standard Standard voltage	V / PH / Hz	400 / 3 / 50	400 / 3 / 50	400 / 3 / 50	400 / 3 / 50	400 / 3 / 50	230 / 1 / 50-60	230 / 1 / 50-60	230 / 1 / 50-60	230 / 1 / 50-60	230 / 1 / 50-60
Peso macchina Machine weight	Kg	227	234	244	252	281	227	234	244	252	281

SF600D
SF600VD
SF600VDX1400+PST

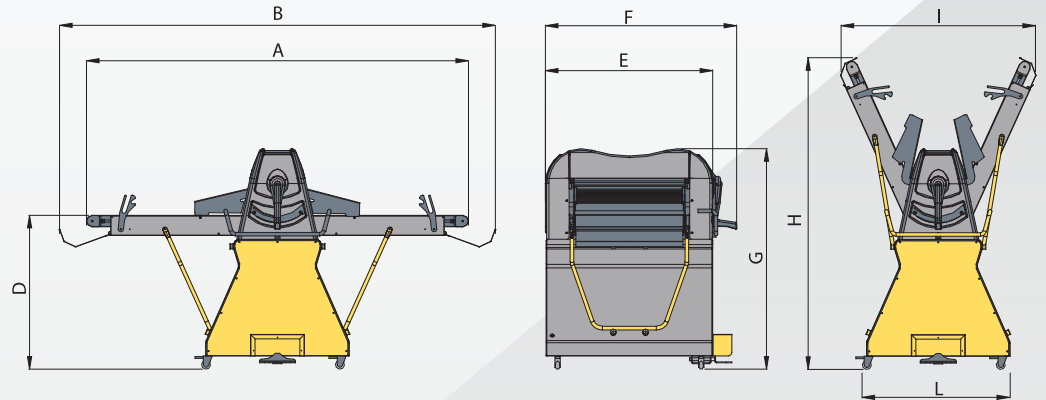

SF600D - 1600
SF600VD - 1600
SF600VDX1600+PST

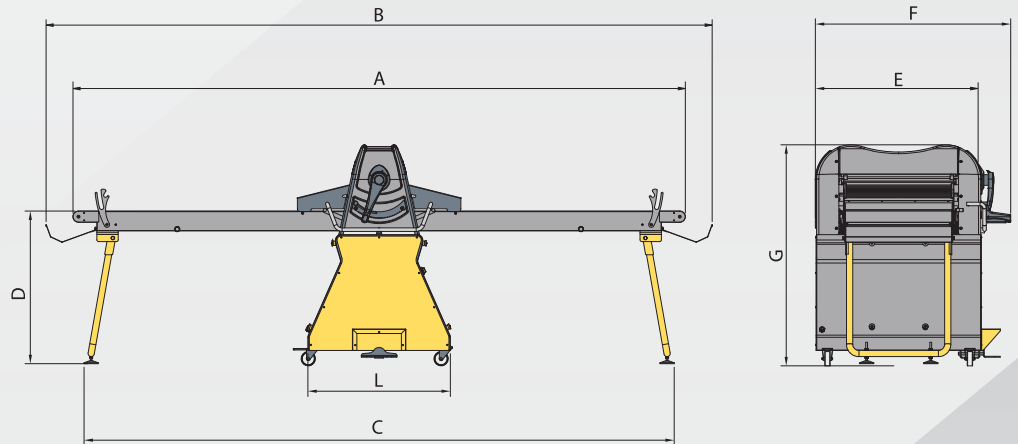

FAST700P
FAST700PAV
FAST700P+PST
FAST700PAV+PST
FAST700
FAST700+PST

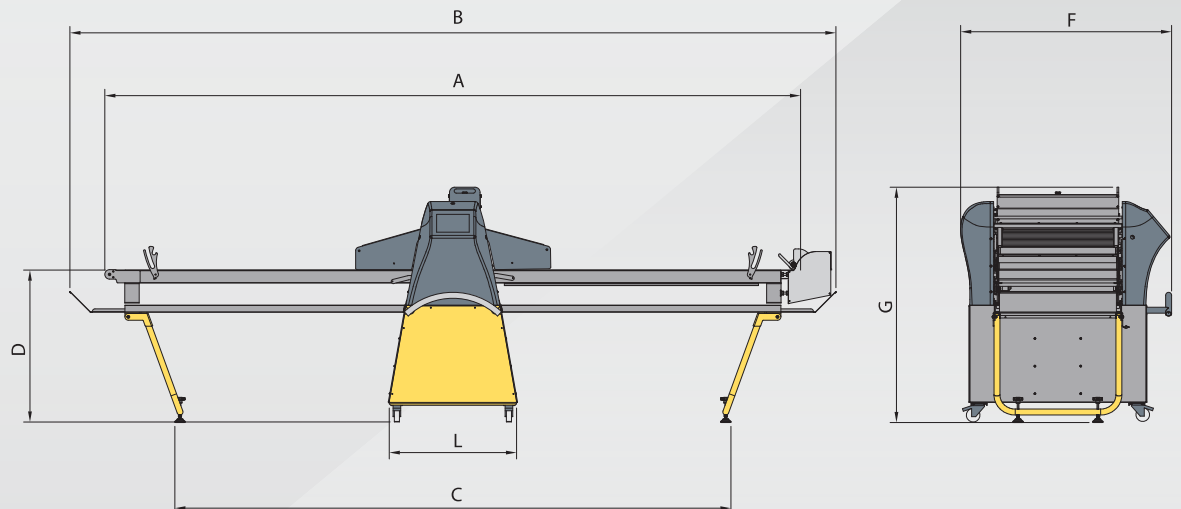

Codice macchina Machine code	A	B	C	D	E	F	G	H	I	L
SF450BDX500	1120	1280	*	300	700	870	570	720	*	430
SF450BDX700	1520	1680	*	300	700	870	570	900	*	430
SF450BVDX500	1120	1280	*	300	700	870	570	720	*	430
SF450BVDX700	1520	1680	*	300	700	870	570	900	*	430
SF450DX500	1120	1280	*	1037	700	870	1307	1457	*	500
SF450DX700	1520	1680	*	1037	700	870	1307	1637	*	500
SF450VDX500	1120	1280	*	1037	700	870	1307	1457	*	500
SF450VDX700	1520	1680	*	1037	700	870	1307	1637	*	500
SF500BDX850	1860	2110	1215	155	770	910	630	890	930	455
SF500BDX1000	2160	2410	1215	155	770	910	630	1050	1040	455
SF500BVDX850	1860	2110	1215	155	770	910	630	890	930	455
SF500BVDX1000	2160	2410	1215	155	770	910	630	1050	1040	455
SF500DX850	1860	2110	*	880	770	910	1335	1620	950	800
SF500DX1000	2160	2410	*	880	770	910	1335	1760	1070	800
SF500DX1200	2560	2810	*	880	770	910	1335	1960	1225	800
SF500VDX850	1860	2110	*	880	770	910	1335	1620	950	800
SF500VDX1000	2160	2410	*	880	770	910	1335	1760	1070	800
SF500VDX1200	2560	2810	*	880	770	910	1335	1960	1225	800
SF600DX850	1860	2190	*	900	920	1065	1225	1619	960	800
SF600DX1000	2160	2490	*	900	920	1065	1225	1757	1180	800
SF600DX1200	2560	2890	*	900	920	1065	1225	1940	1350	800
SF600DX1400	2960	3240	*	900	920	1065	1225	2123	1540	800
SF600DX1600	3480	3810	3314	900	920	1065	1225	*	*	800
SF600VDX850	1860	2190	*	900	920	1065	1225	1619	960	800
SF600VDX1000	2160	2490	*	900	920	1065	1225	1757	1180	800
SF600VDX1200	2560	2890	*	900	920	1065	1225	1940	1350	800
SF600VDX1400	2960	3240	*	900	920	1065	1225	2123	1540	800
SF600VDX1600	3480	3810	3314	900	920	1065	1225	*	*	800
SF600VDX1400+PST	2960	3240	*	900	920	1065	1225	2123	1540	800
SF600VDX1600+PST	3480	3810	3314	900	920	1065	1225	*	*	800
FAST700PX1500	3100	3550	2276	895	*	1243	1386	*	*	750
FAST700PX2000	4100	4550	3276	895	*	1243	1386	*	*	750
FAST700PAVX1500	3100	3550	2276	895	*	1243	1386	*	*	750
FAST700PAVX2000	4100	4550	3276	895	*	1243	1386	*	*	750
FAST700PX1500+PST	3100	3550	2276	895	*	1243	1386	*	*	750
FAST700PX2000+PST	4100	4550	3276	895	*	1243	1386	*	*	750
FAST700PAVX1500+PST	3100	3550	2276	895	*	1243	1386	*	*	750
FAST700PAVX2000+PST	4100	4550	3276	895	*	1243	1386	*	*	750
FAST700X1500	3100	3550	2276	895	*	1243	1386	*	*	750
FAST700X2000	4100	4550	3276	895	*	1243	1386	*	*	750
FAST700X1500+PST	3100	3550	2276	895	*	1243	1386	*	*	750
FAST700X2000+PST	4100	4550	3276	895	*	1243	1386	*	*	750
BT650 - 275	2750	3230	*	870	920	1456	1185	*	*	656
BT650 - 375	3750	4230	*	870	920	1456	1185	*	*	656
BT650 - 475	4750	5230	*	870	920	1456	1185	*	*	656