

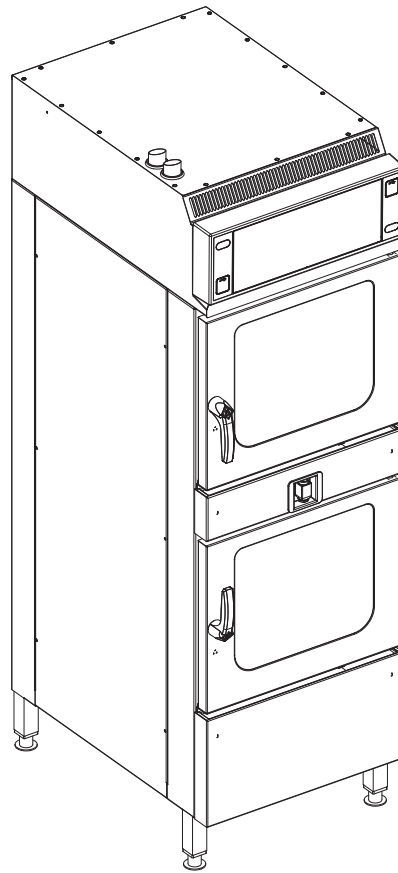

Read the operating instructions prior to commissioning

Operating instructions

Combisteamer



Translation from the original document • 4127003--0ABDE-E • 15/11/2022

Unit	Model	Energy type	Version
SpaceCombi Team	TKECOD6100	Electric	WaveClean 4-point core temperature sensor Software version: 2.0

4127003--0ABBE-E

en-GB

Operating and display elements

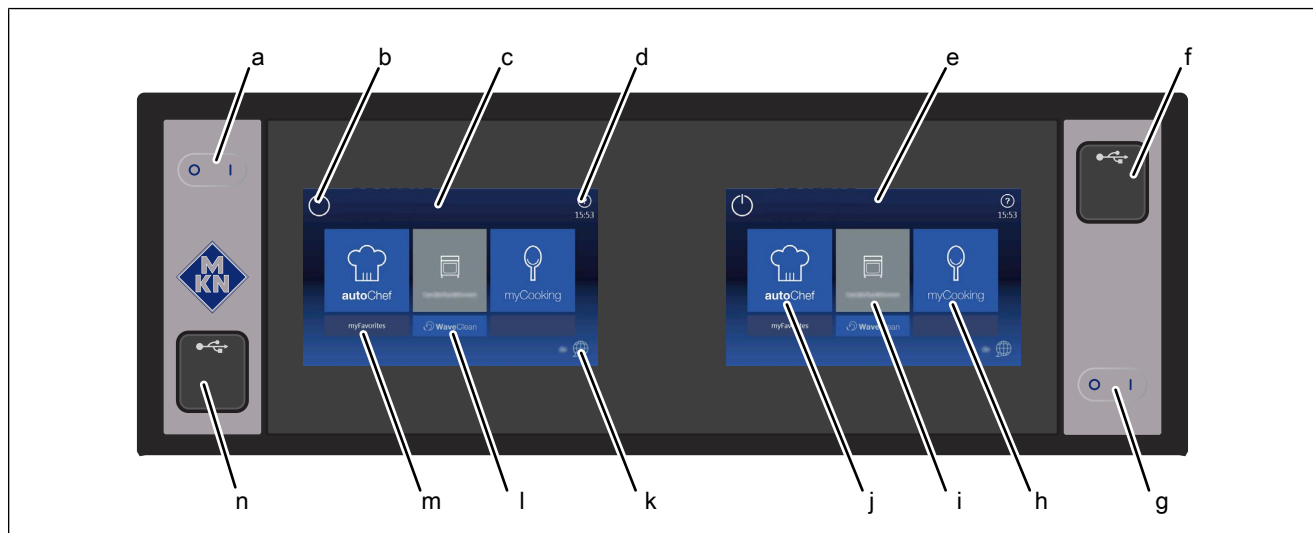

- | | |
|--|------------------------------------|
| a <i>On Off</i> "I O" button for top unit | h "Manual cooking" button |
| b <i>Standby</i> button | i "Unit functions" button |
| c Operating element with touchscreen for top unit | j "Automatic cooking" button |
| d <i>Help</i> button | k <i>Language selection</i> button |
| e Operating element with touchscreen for bottom unit | l <i>WaveClean</i> button |
| f USB port for bottom unit | m "myFavorites" button |
| g <i>On Off</i> "I O" button for bottom unit | n USB port for top unit |

Manufacturer

MKN Maschinenfabrik Kurt Neubauer GmbH & Co. KG
Halberstädter Straße 2a
38300 Wolfenbüttel
Germany

Phone +49 5331 89-0
Fax +49 5331 89-280
Internet www.mkn.com

Copyright

All rights to text, graphics and pictures in this documentation are held by MKN Maschinenfabrik Kurt Neubauer GmbH & Co. KG. Distribution or duplication is only permitted with the prior written consent of MKN.

Copyright by MKN Maschinenfabrik Kurt Neubauer GmbH & Co. KG.



1 Introduction	9
1.1 About this manual	9
1.1.1 Explanation of signs	10
1.2 Intended use	11
1.3 Warranty	11
2 Safety information	12
3 Description of the unit	15
3.1 Overview of the unit	15
3.2 Features	16
3.2.1 Characteristics	16
3.2.2 HACCP logging	17
3.2.3 VideoAssist	17
3.2.4 WaveClean automatic cleaning	17
3.3 Operating and cooking modes	17
3.3.1 Operating modes	17
3.3.2 Types of cooking	18
3.3.3 Expanded cooking functions	19
3.3.4 Core temperature measurement	21
3.4 MagicPilot equipment controls	22
3.5 Loading capacity	23
3.5.1 Plate capacity during regeneration	23
3.5.2 Loading capacity	24
3.6 Standard setting values	24
3.6.1 Temperature standard setting	24
3.6.2 Core temperature standard setting	24
3.6.3 Cooking zone humidity standard setting	24
4 Operating the unit	25
4.1 Operating the unit in an environmentally responsible manner	25
4.2 Switching the unit on and off	26
4.2.1 Switching on	26
4.2.2 Switching off	26
4.3 Opening and closing the cooking zone door	26
4.3.1 Open	26
4.3.2 Close	27
4.4 Loading and emptying the unit	27
4.4.1 Loading	27
4.4.2 Emptying	27
4.5 Equipment functions menu	28
4.5.1 Controlling the main menu	28
4.5.2 Opening the equipment functions menu	29

4.5.3 Changing the basic settings	29
4.5.4 Retrieving equipment information	31
4.5.5 Setting the date and time	31
4.5.6 Presetting the language selection	32
4.5.7 Setting favourites	33
4.5.8 Activating and cancelling inhibit operation	33
4.5.9 Setting the background lighting	34
4.5.10 Setting the water filter maintenance	35
4.5.11 Possible settings in the parameter level	35
4.5.12 Importing video	37
4.5.13 Importing images	37
4.5.14 Importing recipes	38
4.6 Basic functions	38
4.6.1 Setting the cooking temperature	38
4.6.2 Setting the cooking time and continuous operation	40
4.6.3 Using start-time preselection	42
4.6.4 Setting the core temperature	43
4.6.5 Setting the fan speed and direction of rotation	44
4.6.6 Using Perfection (regeneration)	45
4.6.7 Using PerfectHold	46
4.6.8 Setting Ready2Cook	47
4.6.9 Using Steam Exhaust System (SES)	48
4.6.10 Using RackControl2	48
4.6.11 Setting Time2Serve	51
4.6.12 Using FamilyMix	52
4.6.13 Using the Continue cooking function	52
4.6.14 Setting manual humidification	54
4.6.15 Setting the rest stage	55
4.6.16 Using QualityControl	56
4.6.17 Using low-temperature cooking	57
4.6.18 Using the barcode scanner	58
4.6.19 Inserting and removing a USB flash drive	59
4.6.20 Preparing a USB flash drive for importing and exporting	59
4.6.21 Exporting the HACCP log	60
4.7 Using the core temperature sensor	60
4.7.1 Measuring with a 4-point core temperature sensor	61
4.7.2 Measuring the core temperature when cooking frozen food	62
4.7.3 Core temperature display with time-controlled cooking process	62
4.7.4 Core temperature display outside the cooking process	63
4.8 Manual cooking	63
4.8.1 Opening the Manual cooking menu	63
4.8.2 Creating a cooking program step	63
4.9 Creating and managing your own cooking programs	65
4.9.1 Creating a cooking program	66

4.9.2 Saving the cooking program	67
4.9.3 Exporting a cooking program	71
4.10 Automatic cooking (autoChef)	72
4.10.1 Opening the Automatic cooking menu	72
4.10.2 Finding and opening a cooking program	72
4.10.3 Starting the cooking program	73
4.10.4 Ending the cooking program	73
4.10.5 Modifying the cooking program	74
4.10.6 Deleting a cooking program	75
4.10.7 Exporting and importing a cooking program	75
4.11 VideoAssist	78
4.11.1 Watching a video	78
4.11.2 Deleting a video	78
4.12 Pausing and finishing use	79
4.12.1 Perform a hygiene flush after an extended period of idleness	79
5 Cleaning and caring for the unit	80
5.1 Preventing corrosion	81
5.2 Remove rust spots	81
5.3 Cleaning the housing	81
5.4 Cleaning the door handle, operating elements and control panel ..	82
5.5 Cleaning the touchscreen	82
5.6 Cleaning the door seal	83
5.7 Cleaning the cooking zone door	83
5.7.1 Cleaning the door with hygienic glazing	83
5.8 Removing calcium deposits from the unit	84
5.9 Cleaning the cooking zone automatically with WaveClean	84
5.9.1 Preparing for cleaning	85
5.9.2 Selecting the cleaning level	85
5.9.3 Inserting the cleaning cartridge	86
5.9.4 Starting automatic cleaning	87
5.9.5 Cancelling automatic cleaning	87
5.9.6 Ending automatic cleaning	87
5.10 Cleaning the cooking zone manually	88
5.10.1 Preparing the cooking zone	88
5.10.2 Starting the cleaning program	88
5.10.3 Spraying the cleaner	88
5.10.4 Allowing the cleaner to act	89
5.10.5 Starting cleaning	89
5.10.6 Drying the cooking zone	89
5.11 Inspecting the unit	89
5.11.1 Performing a visual inspection	89
6 Troubleshooting	90

6.1 Emergency mode	90
6.2 Nameplate	90
6.2.1 Explaining nameplate information	90
6.3 Causes of errors and remedies	91
7 Carrying out maintenance	92
8 Dispose of unit in an environmentally responsible manner	93
9 Manufacturer's declaration	94
Keyword index	97



1 Introduction

1.1 About this manual

The operating instructions are part of the unit and contain information:

- On safe operation,
- On cleaning and care,
- On remedies in case of faults.

Be aware of the following notes and adhere to them:

- Read the operating instructions completely before operating the unit for the first time.
- Make the operating instructions available to the operator at all times at the operating site of the unit.
- Insert any supplements from the manufacturer.
- Keep the operating instructions throughout the service life of the unit.
- Pass on the operating instructions to any subsequent operator of the unit.

Target group The target group of the instruction manual is the operator, who is entrusted with the operation, cleaning and care of the unit.

Figures All figures in this manual are intended as examples. Discrepancies between these and the actual unit can arise.

1.1.1 Explanation of signs



DANGER
Imminent threat of danger

Failure to comply will lead to death or very severe injuries.



WARNING
Possible threat of danger

Failure to comply can lead to death or very severe injuries.



CAUTION
Dangerous situation

Failure to comply can lead to slight or moderately severe injuries.

ATTENTION
Physical damage

Failure to comply can cause physical damage.



Notes for better understanding and operation of the unit.

Symbol / sign	Meaning
•	Listing of information.
→	Action steps, which can be performed in any sequence.
1. 2.	Action steps, which must be performed in the specified sequence.
↳	Result of an action performed or additional information about it.

1.2 Intended use

This unit is intended to be used solely for commercial purposes, particularly in commercial kitchens.

This unit may only be used with suitable accessories and for the cooking of food.

It is forbidden to use the unit for purposes, which include the following:

- Washing dishes
- As set-down area in or on the unit
- Storing supplies
- Drying cloths, paper or dishes
- Heating acids, alkaline solutions or other chemicals
- Heating preserved food
- Heating flammable liquids
- Heating rooms
- Cleaning air filters

The use of the unit is prohibited in the following countries:

- USA
- Canada

1.3 Warranty

The warranty is void and safety is no longer assured in the event of:

- Improper conversion or technical modifications of the unit,
- Improper use,
- Incorrect startup, operation or maintenance of the unit,
- Problems resulting from failure to observe these instructions.

2 Safety information

The unit complies with applicable safety standards. Residual risks associated with operation or risks resulting from incorrect operation cannot be ruled out and are mentioned specifically in the safety instructions and warnings.

The operator must be familiar with regional regulations and observe them.

Operation Individual below 16 years of age are not allowed to operate, maintain or clean the unit.

During operation, the following group of individuals must be supervised by an individual who is responsible for safety:

- Individuals with physical, sensory, or mental handicaps, or who lack the knowledge and experience to operate the unit properly.

The supervising individual must be familiar with the unit and the risks associated with it.

Do not allow children to operate, clean or play with the appliance.

Hot surfaces Risk of burns from hot surfaces

- Protect arms and hands by wearing suitable protective gloves.
- Allow surfaces to cool prior to cleaning.
- Remove hot cookware only with suitable protective gloves or potholders.
- Remove containers and baking sheets only with suitable protective gloves or potholders.

Hot liquids Risk of burns from hot liquids

- Protect arms and hands by wearing suitable protective gloves.
- Remove, transport and empty containers carefully.

Risk of chemical burns from evaporating cleaners

- Follow the instructions of the cleaning agent manufacturer.
- Allow the cooking so to clean to a temperature below 60 °C and then clean.

Risk of burns from steam

- Protect arms and hands by wearing protective gloves.
- Do not hold hands in front of the extractor hood.
- First open the cooking zone door slightly and allow the steam to escape. Then open the cooking zone door completely.
- Dry unit completely after cleaning it.

Defective unit Risk of injury from a defective unit

- Disconnect a defective unit from the electric mains.
- Do not operate a defective unit.
- Allow only an authorized technician to repair the unit.

Fire prevention Risk of fire from dirt and grease deposits

- Clean the unit when finished using it.
- Do not use the unit as a deep fat fryer.
- Clean the cooking zone regularly and remove any fat deposits.

Risk of fire from overheating

- Do not store any combustible objects or plastic containers in the cooking zone.

Firefighting

- In the event of a fire, disconnect the unit from the electric mains.
- Use a Fire Class F fire extinguisher, never water, to extinguish grease fires. Other fires, for instance, can be extinguished with fire extinguishers suitable for Fire Classes A, B, C, CO₂ fire extinguishers or extinguishing media suitable for the fire class confronted.

Improper cleaning Risk of chemical burns from cleaning agent

- Follow the instructions of the cleaning agent manufacturer.
- Take appropriate protective measures when handling aggressive cleaning agents.

Risk of falling on smooth or slippery floor

- Keep the floor in front of the unit clean and dry.

Risk of injury from improper cleaning

- Clean the cooking zone carefully. The cooking zone sensor protrudes into the cooking zone.

Risk of physical damage from improper cleaning

- Clean the unit after using it.
- Do not clean the unit with a high-pressure cleaner or water jet.
- Do not clean the housing with highly abrasive or chemically aggressive cleaning agents.
- Do not clean the housing with highly abrasive sponges.
- Follow the instructions of the cleaning agent manufacturer.
- Do not cool shock the unit by cooling it abruptly.
- Clean the cooking zone carefully. The cooking zone sensor protrudes into the cooking zone.
- Do not use any bleaching or chlorine-containing cleaners or disinfectants.
- Remove rust spots with an abrasive.
- Keep the unit free of calcium deposits.

Hygiene Health risk from insufficient hygiene

- Observe applicable regional hygiene regulations.

Core temperature measurement Risk of injury from overheated core temperature sensor

- Do not heat the core temperature sensor over an open flame.

Improper use Risk of physical damage from improper use

- Use only original accessories.
- Train operators regularly.
- Do not heat food warmer plates or tins of preserved food.
- Do not cover air inlet and outlet openings.
- Do not operate the unit at temperatures below 4° C.
- Remove the core temperature sensor before the cooked food is removed.
- Insert the core temperature sensor back into the holder after use.

3 Description of the unit

The unit is a convection steamer, which is suitable for most cooking methods used in commercial kitchens. It can be used with either Convection or unpressurised live steam, either individually, in sequence, or in conjunction with moist or dry heat.

3.1 Overview of the unit

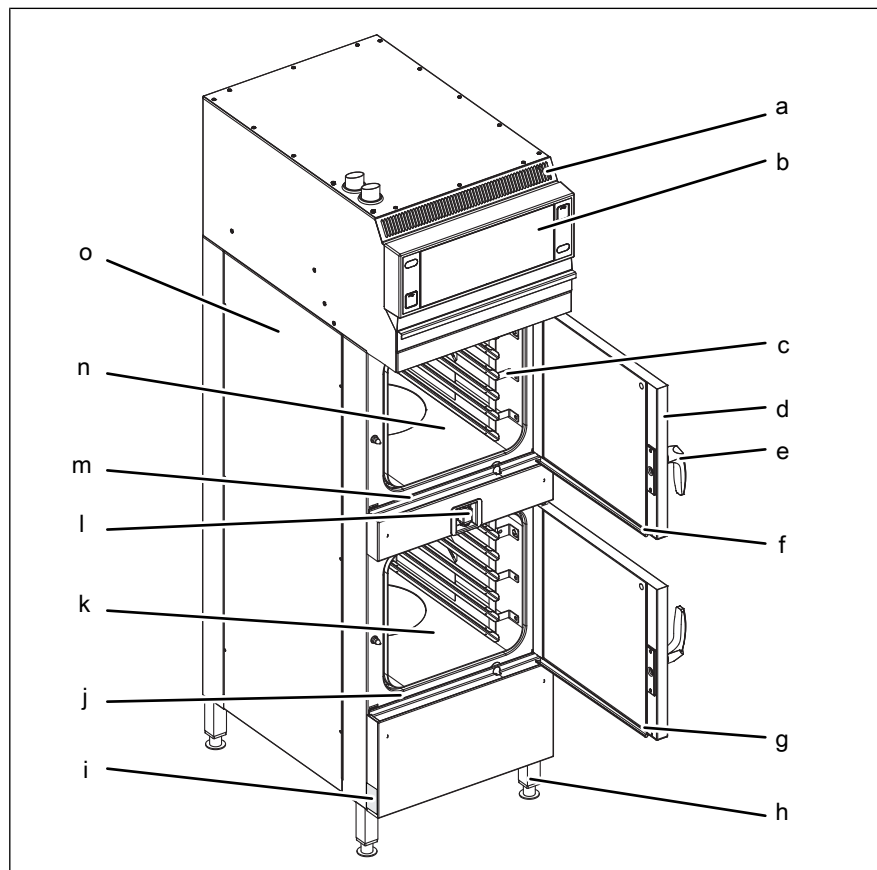

Image: SpaceCombi Team

- | | |
|-------------------------------------|-------------------------------------|
| a Air outlet | i Nameplate |
| b Control unit | j Discharge channel for bottom unit |
| c Support rack | k Cooking zone in bottom unit |
| d Cooking zone door | l Hand shower (optional) |
| e Door handle | m Discharge channel for top unit |
| f Discharge channel for top door | n Cooking zone in top unit |
| g Discharge channel for bottom door | o Housing |
| h Equipment leg | |

3.2 Features

3.2.1 Characteristics

- Cooking zone door with hygienic glazing
- Halogen cooking zone lighting
- 4-point core temperature sensor
- 1-stage door lock
- Power optimisation system (optional)
- Cooking zone door hinged at right
- Cooking zone door hinged at left (optional)
- Barcode scanner (optional)
- USB interface
- Ethernet interface

Software

- Import function for cooking programs
- Cooking program protection
- Favourites
- ChefsHelp
- QualityControl
- VideoAssist
- FamilyMix
- Time2Serve
- PerfectHOLD
- ClimaSelect plus
- GreenInside
- Eco mode
- PHleco DynaSteam2
- Steam Exhaust System (SES)
- Perfection
- Ready2Cook
- RackControl
- Start-time preselection
- WaveClean (optional)

3.2.2 HACCP logging

All cooling programs run are recorded in the HACCP log.

The data are exported via the USB port.

3.2.3 VideoAssist

VideoAssist can be used to display videos with additional explanations regarding operation.

3.2.4 WaveClean automatic cleaning

With WaveClean automatic cleaning, the cooking zone is cleaned with the aid of a cleaning cartridge intended specifically for the program and then rinsed clean.

3.3 Operating and cooking modes

3.3.1 Operating modes



Manual cooking (myCooking)

In the manual cooking mode, individual Cooking modes and Equipment functions can be executed directly. The different cooking modes and Equipment functions can be individually adjusted.



Automatic cooking (autoChef)

In the automatic cooking mode, saved cooking programs can be executed and adjusted if necessary.

3.3.2 Types of cooking



Steaming

Steaming is a cooking mode, in which the food to be cooked is cooked gently by means of steam in a temperature range of 30 °C to 130 °C.



Combisteaming

Combisteaming is a cooking mode, in which the Steaming and Convection cooking modes are combined. The temperature range extends from 30 °C to 250 °C.

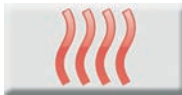

Convection

Convection is a cooking mode, in which the food to be cooked is cooked without additional moisture in a temperature range of 30 °C to 300 °C.



Perfection (regeneration)

Perfection is a cooking mode that can be used to prepare cooled cooked food quickly in a temperature range of 30 °C to 180 °C and then keep it warm.



Delta-T cooking

Delta-T cooking is a cooking mode, in which the cooking temperature depends on the core temperature of the food being cooked.



The cooking temperature is always higher than the current core temperature by the set value (Delta-T value, cooking temperature difference). The resulting cooking time is longer than with other cooking modes.



Delta-T cooking is particularly well-suited for gentle cooking. The food being cooked remains tender and juicy with little weight loss.



Low-temperature cooking

Low-temperature cooking is a cooking mode where the food to be cooked is cooked in an especially gentle manner in a temperature range of 30 °C to 100 °C.

The cooking time is considerably longer than at higher temperatures, but no supervision is required and the cooking time can be extended considerably without any loss in quality.

The food being cooked remains tender and juicy with little weight loss.



Baking

Baking is a cooking mode, in which the texture of the food to be cooked is loosened and then cooked and browned by Convection in a temperature range of 30 °C to 220 °C. Before baking takes place, a humidifying process with its associated acting time can be performed.

3.3.3 Expanded cooking functions

Expanded cooking functions can be used to modify individual cooking steps for the particular food being cooked.

The following expanded cooking functions are available:



PerfectHOLD

PerfectHOLD is a cooking function, in which the food to be cooked is kept warm in the unit at a temperature range of 50 °C to 100 °C after the actual cooking process, until it is ready to be served.



Ready2Cook (preheating)

For many cooking programs such as baking for example, the correct starting temperature is important.

With Ready2Cook, the cooking zone can automatically be heated or cooled to the correct starting temperature.

A screen-filling display gives information during the procedure about the status.



Start-time preselection



When using the start time delay, temperatures that promote the growth of harmful microorganisms on the food being cooked can occur in the cooking zone. Observe food processing regulations.

Start-time preselection allows a waiting period to be set until the program starts.

In this way, bottlenecks in production and preparation can be avoided.

The prepared food to be cooked can be loaded into the unit and the desired cooking program selected.



Steam Exhaust System (SES)

This function is activated as standard for all cooking programs that have a cooking time longer than 6 minutes.

The Steam Exhaust System (SES) is activated automatically shortly before the end of cooking.

After the cooking time has elapsed, the Steam Exhaust System (SES) extracts the steam from the cooking zone. It is then possible to open the cooking zone door without risk of injury.



RackControl2

RackControl is ideal for rolling cooking.

With the extended RackControl2 cooking function, different foods such as potatoes, cauliflower, peas, carrots and meat can be cooked simultaneously for different times.

RackControl2 monitors the various cooking times in one process. When a cooking time has elapsed, a signal sounds and the food being cooked can be removed.

The set temperature can be changed during an active cooking process, without the process having to be stopped.



ChefsHelp

The extended ChefsHelp cooking function allows a cooking step to be inserted, which at a certain time gives the user further help information through text and images.



FamilyMix

With the extended FamilyMix cooking function, the appropriate cooking programs for the currently set cooking mode are displayed from the *Automatic cooking (autoChef)* menu. The cooking programs displayed have the same cooking climate and an identical or shorter cooking time. Tapping the individual suggestions transfers the cooking times for the particular products to the RackControl function, and these can then be started during cooking when desired.



Manual humidification

The extended Manual humidification cooking function allows the cooking humidity to be increased during operation.

Manual humidification can only be used in the Convection and Delta-T Convection cooking modes.

The remaining time for this procedure is displayed during humidification. After the Drop symbol has been touched, the set value is displayed for 3 seconds.



Resting time

With the extended Resting time cooking function, a cooking step can be inserted during which the heating and the fan are programmed to switch off for a certain period of time.



QualityControl

The extended QualityControl cooking function enables the control system to detect by itself the loading volume and to adjust the particular cooking parameters in autoChef. This ensures that there is always first-class quality.



After-cooking button

The After-cooking button allows the cooking process to continue for a previously defined time, after the cooking program has elapsed.

DynaSteam²

The DynaSteam² function is used to match the required amount of steam to the product volume of the food being cooked. The steam with is finely adjusted and automatically introduced into the cooking zone.

Time2Serve



Using the extended Time2Serve cooking function, different products can be ready to serve at the same time.

The serving time is specified. The Combisteamer gives a message, when a remaining cooking time for a product is reached. A signal sounds and the food to be cooked is loaded in succession during an active cooking process. The cooking time is reduced and resources saved.



ClimaSelect plus

The extended ClimaSelect plus cooking function optimises the climate in the cooking zone. Steam is introduced in small stages, and the climate can be controlled individually.

3.3.4 Core temperature measurement

When using core temperature measurement, the temperature inside the food being cooked is measured by means of a core temperature sensor.

As soon as the target core temperature is reached, the cooking process is ended automatically or, in the case of a multi-step cooking process, the next cooking step starts.

The use of core temperature measurement offers the following benefits:

- Reduced energy and water consumption
- No overcooking
- Less weight lost by the food being cooked
- High HACCP safety

3.4 MagicPilot equipment controls

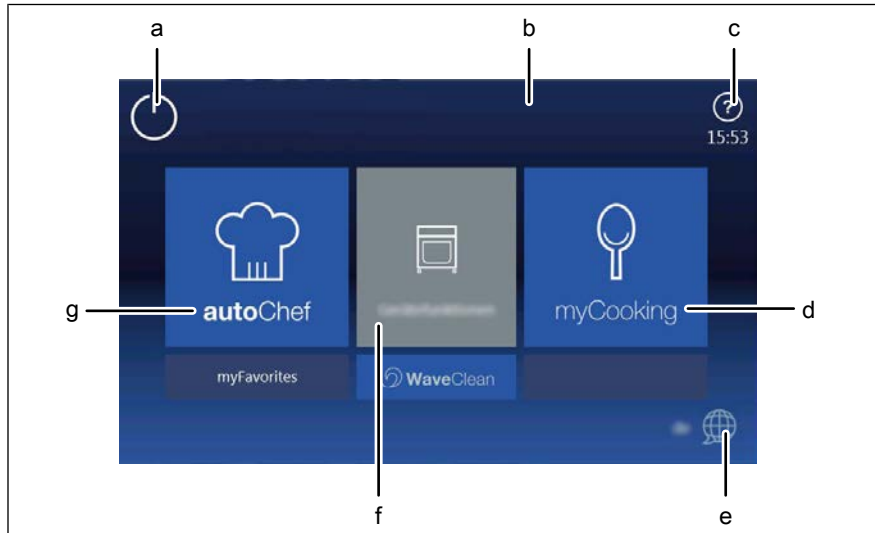

Image: Main menu

- a *Stand-by* button
- b Information bar
- c *FlexiHelp* button
- d "myCooking" button
- e *Language selection* button
- f "Equipment functions" button
- g "autoChef" button

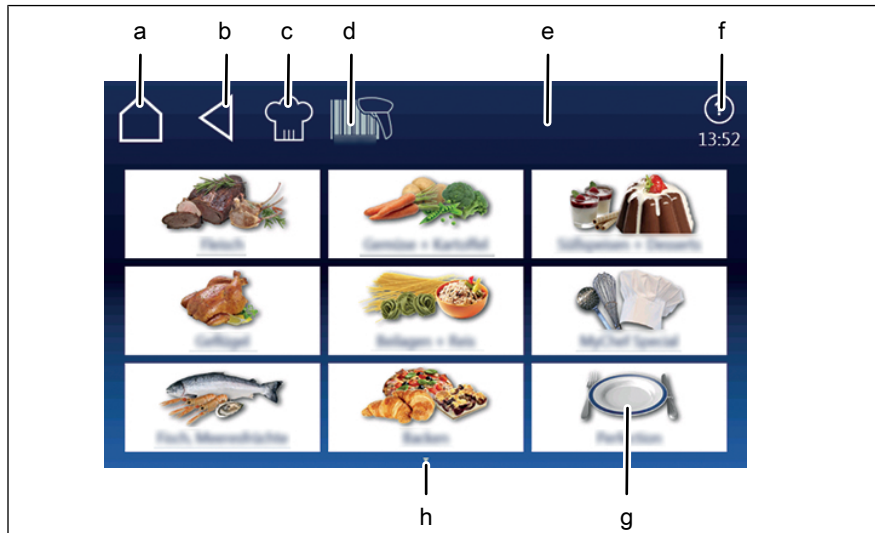

Image: Automatic cooking menu, autoChef

- a *Main menu* button
- b *Back* button
- c *autoChef* button
- d *Barcode Scanner* button
- e Information bar
- f *FlexiHelp* button
- g *Category* field
- h *next page* arrow symbol

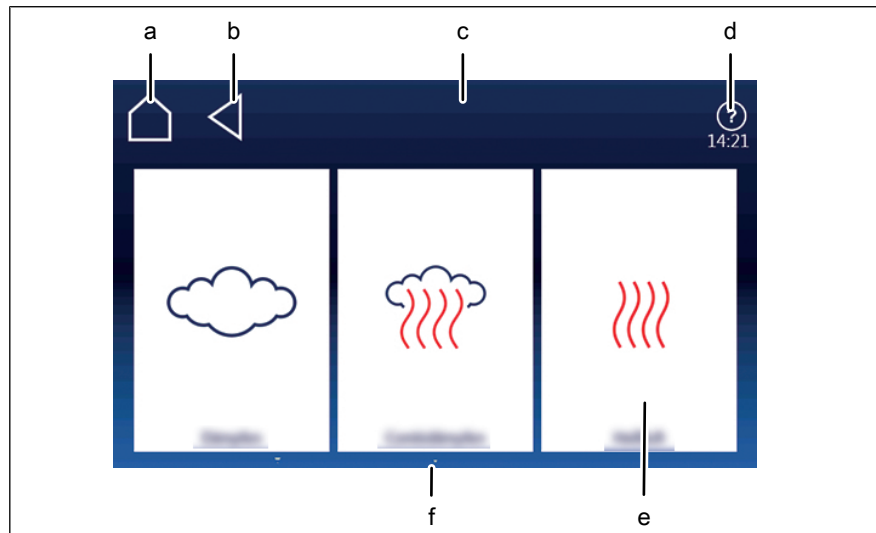

Image: Manual cooking menu

- a *Main menu* button
- b *Back* button
- c Information bar
- d *FlexiHelp* button
- e "Convection" field
- f *next page* arrow symbol

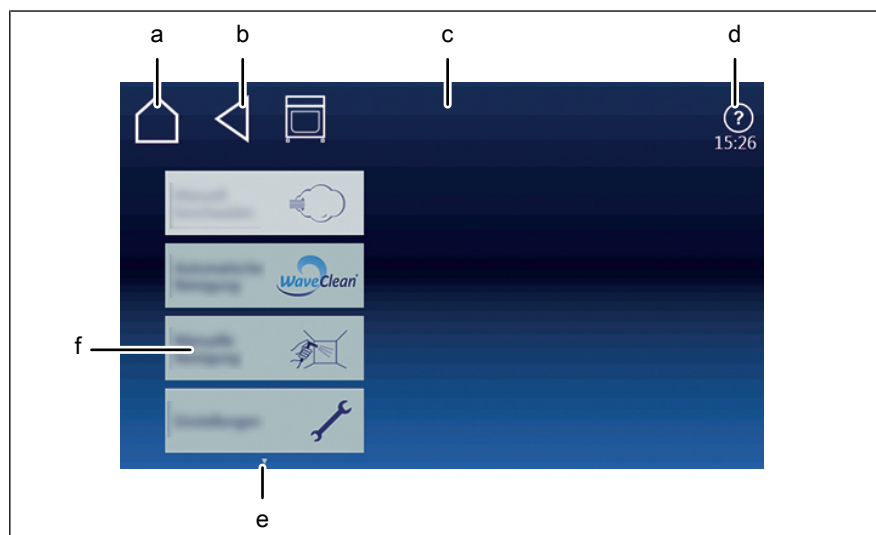

Image: Equipment functions menu

- a *Main menu* button
- b *Back* button
- c Information bar
- d *FlexiHelp* button
- e *next page* arrow symbol
- f *Manual cleaning* field

3.5 Loading capacity

3.5.1 Plate capacity during regeneration

The cooking time and cooking temperature depend on the number of plates in the cooking zone.

Version	Plate diameter
	28 cm
610	12 per cooking zone

3.5.2 Loading capacity

Version	Per shelf maximum (kg)	Per cooking zone maximum (kg)
610	15	30

3.6 Standard setting values

3.6.1 Temperature standard setting

The adjustment range for the cooking zone temperature depends on the cooking mode.

Cooking mode	Standard value (°C)	Adjustment range (°C)	Alteration increments (°C)
Steaming	100	30 - 130	1
Combisteaming	150	30 - 250	1
Convection	180	30 - 300	1
Regeneration	50	30 - 180	1

3.6.2 Core temperature standard setting

The adjustment range for the core temperature depends on the cooking mode.

Cooking mode	Standard value (°C)	Adjustment range (°C)	Alteration increments (°C)
Steaming	70	0 - 99	1
Combisteaming	70	0 - 99	1
Convection	70	0 - 99	1
Regeneration	50	0 - 99	1

3.6.3 Cooking zone humidity standard setting

The adjustment range for the cooking zone humidity depends on the cooking mode.

Cooking mode	Standard value (%)	Setting range (%)	Change increments (%)
Steaming	100	90 - 110	90 - 100 - 110
Combisteaming	90	20 - 100	20 - 40 - 70 - 90 - 100
Convection	100	0 - 100	0 - 25 - 50 - 75 - 100
Regeneration	100	0 - 100	0 - 25 - 50 - 75 - 100

4 Operating the unit



Explanatory video clips can be selected under VideoAssist by press the Help button.



Reduction of acrylamide level

Regulation EU 2017/2158 has applied in Europe since 2018-04-11.

This requires that the lowest possible acrylamide level must be achieved when cooking potato products.

MKN therefore recommends the following for potato products:

- Do not exceed a cooking temperature of 220 °C, unless the food manufacturer states, that this is safe for his product.
- Avoid excessive cooking.
- If possible, use pre-blanching products.
- Observe the cooking instructions on the product packaging or otherwise stated by the food manufacturer.



The drain in the cooking zone must be free during operation.

Before loading the cooking zone

- Remove any food remains from the cooking zone.
- Check the drain sieve for cleanliness.
- Do not place GN containers or trays on the drain in the cooking zone.

ATTENTION

Blockage of the drain in the cooking zone

Food debris, skin and bones can clog the drain and pump.

- For very fatty food, place a sieve or perforated GN container in the lowest rack.
- After each cooking process, take a close look in the cooking chamber and pick up any residues and dispose of them properly.

4.1 Operating the unit in an environmentally responsible manner

If used correctly, this Combisteamer achieves very low energy consumption.

Energy consumption is reduced by:

- Avoiding continuous operation - the Combisteamer heats up very quickly, which means that continuous operation is not necessary.
- Loading the cooking zone as fully as possible - if practical, use a Combisteamer with a smaller cooking zone.

4.2 Switching the unit on and off

4.2.1 Switching on

- Press the *On Off "I O"* button to "I".
 - ↳ The unit is now on.
 - ↳ The control system starts the power-on process automatically. The progress bar at the lower edge of the touchscreen displays the status of the process.
- ↳ The main menu appears after 1 minute and the unit is ready for use.

4.2.2 Switching off



Fans may continue to run for cooling; the unit's control system is disconnected from power.

- Press the *On Off "I O"* button to "O".
 - ↳ The unit is now off.

4.3 Opening and closing the cooking zone door

4.3.1 Open

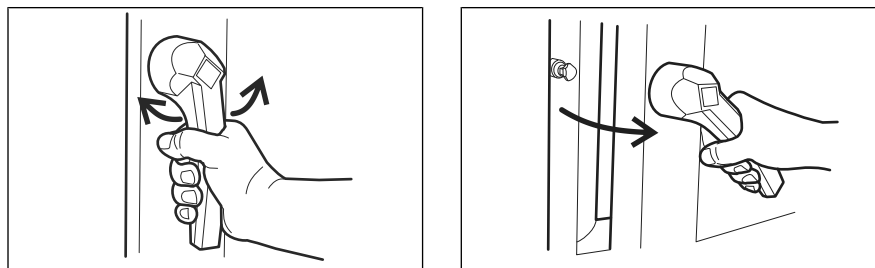

Image: Opening the single-stage door latch

1. Rotate the door handle anti-clockwise or clockwise.
 - ↳ The cooking zone door opens.



If the door handle is released, it returns automatically to its initial position.

2. Open the cooking zone door completely.

4.3.2 Close

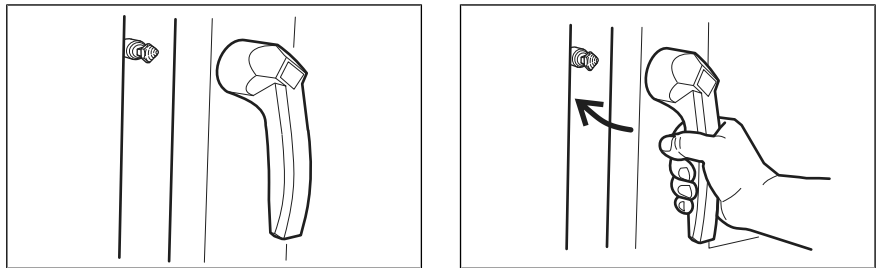

Image: Closing the single stage door latch

Requirement Door handle in initial position

→ Close the cooking zone door with pressure.

↳ The cooking zone door is closed.

4.4 Loading and emptying the unit



CAUTION

Risk of burns from hot liquid

- Never insert a food-carrying tray with cooking liquid or goods, that will get liquid, above eye level.
- Use only suitable trays to hold food. The food-containing trays must rest securely on the support brackets.
- Always insert the food-containing trays into the U-rails.



CAUTION

Risk of physical damage and personnel injury from exceeding the loading capacity

- Do not exceed the maximum loading capacity.



To not use bent or damaged support racks.

4.4.1 Loading

1. Open cooking zone door.
2. Insert food-containing trays into the support racks.
3. Close the cooking zone door.
4. Start the cooking process.

4.4.2 Emptying

1. Open cooking zone door.
2. Remove the food-containing trays.
3. Remove all food residues from the drain screen.
4. Leave the cooking zone door slightly ajar.
 - ↳ This extends the service life of the door seal.
 - ↳ No moisture builds up in the cooking zone.

4.5 Equipment functions menu

Various functions or settings can be selected in the *Equipment functions* menu.



All equipment functions can also be accessed from within a cooking program by tapping the *blue* tab.

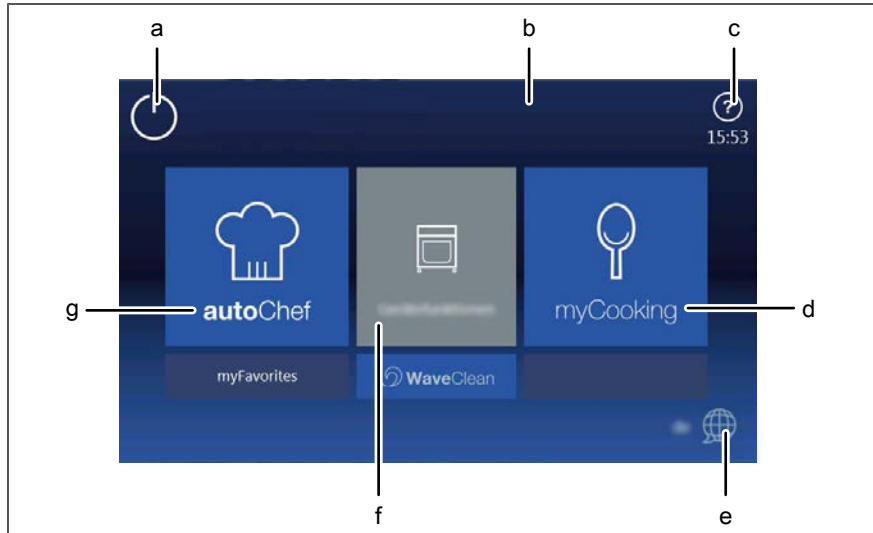

Image: Main menu

- | | | | |
|---|--------------------|---|------------------------------|
| a | Stand-by button | e | Language selection button |
| b | Information bar | f | "Equipment functions" button |
| c | FlexiHelp button | g | "autoChef" button |
| d | "myCooking" button | | |



The equipment information is displayed without entering a password.

4.5.1 Controlling the main menu



The main menu can be directly controlled from each program step.

Requirements *Cooking program* or *Settings* menu called up



1. Tap the *Back* button.
 - ↳ The previous menu or program step is displayed.
2. If necessary, repeat several times.
3. Tap the *Back* button twice.
 - ↳ All program steps are bypassed.
 - ↳ The display shows the main menu.

4.5.2 Opening the equipment functions menu

Requirement The unit is switched on
The Main menu is displayed

- Tap the "Equipment functions" button.
- ↳ The *Equipment functions* menu is displayed.

4.5.3 Changing the basic settings



The basic settings for operation can be displayed, changed and exported by entering the password "1111".

Calling up the settings menu

Requirement *Equipment functions* menu open

1. Tap on "Equipment settings" field.
- ↳ The *PIN* window opens.

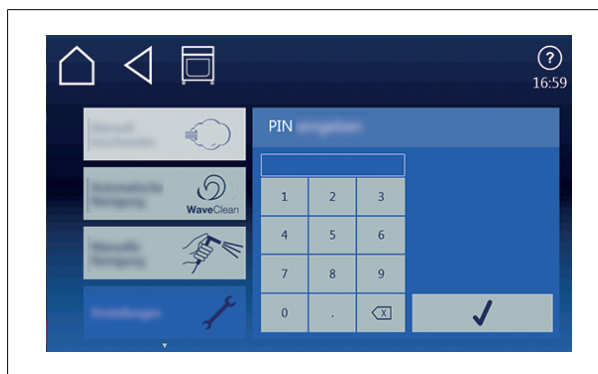

2. Set password.
3. Tap on *Confirmation* button.
- ↳ The *Equipment settings* menu is displayed.
- ↳ Basic settings can be changed.

In addition to those described in this chapter, there are the following further functions.

Audio settings

Selection of the volume of the signal tones.

Operation lock

Various settings depending on whether and when the operation lock is to be activated.

Entering and changing the code word.

Stand-by mode

To set the stand-by mode, deactivate the operating lock.

If stand-by mode is activated, the touchscreen goes dark after the set time. The cooking zone light is switched off.

Setting the background lighting

This setting reduces the brightness of the touchscreen.

Delete user's own cooking programs

Delete all the cooking programs created by the user.

Set the units

Set the units for temperature and liquid quantities.

The possibilities for temperature are °C and °F.

The possibilities for volume are ml, fl.oz (Imp.) and fl.oz (US)

Display the fault memory

Call up stored faults for forwarding to Service partners.

Import HansDampf programs

Import existing HansDampf programs.

Importing manufacturer's cookbook

Import the cookbooks provided by the manufacturer.

Select cookbook

Select the cookbooks typical of the country.

Cookbook lock

Lock function for the cooking programs in autoChef.

Setting	Function
Unlocked	Deleting, changing and overwriting the cooking programs is possible
Locked	Changes in the cooking steps, for example temperature increases, are possible. The preset values apply again, when the cooking program is next called up.
Fully locked	The cooking program can only be used in the way it has been stored. Changes in the cooking steps are not possible.

Export log data

Export of log data for forwarding to the service technician.

Load OEM settings

Special settings can be loaded.

Eco display On or Off

Set the Eco display function.

Select signal tones

Selection of one of the four possible signal tones.

Software update

Update of the software via a USB flash drive.

Import additional content

Import of additional content via a USB flash drive.

4.5.4 Retrieving equipment information



The equipment information contains details about the software and hardware version, the serial number of the unit and contact details.

Requirement The *Setting* menu is displayed



- Tap the "Equipment information" field.
- ↳ The *Equipment information* window is displayed.
- ↳ Equipment information can now be read.

4.5.5 Setting the date and time



Observe the displayed date and time format carefully. If values are invalid, the entry is not accepted.

Requirement The *Settings* menu displayed

1. Tap on "Set date and time" field.
- ↳ The *Setting* window is opened.
- ↳ *Keypad* is opened.

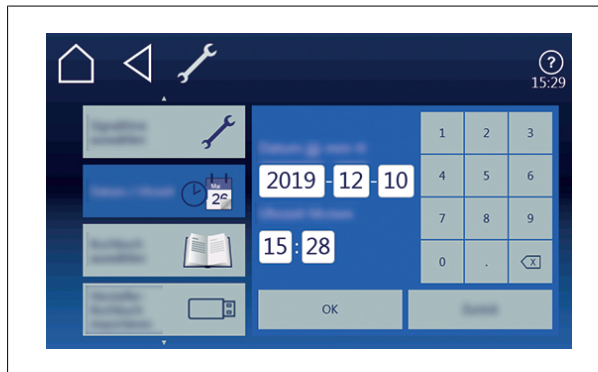

2. Set date and time.
3. Tap on confirm button.
- ↳ *Keypad* is closed.
- ↳ Date and time are set.

4.5.6 Presetting the language selection



A maximum of 5 languages can be specified for language selection in the main menu.



Highlighted fields represent the specified languages.

Fields that are not highlighted are languages that have not been specified.



The currently set language cannot be deselected.

Requirement The *Settings* menu displayed

1. Tap on "Select languages" field.
↳ The *Languages* menu is displayed.

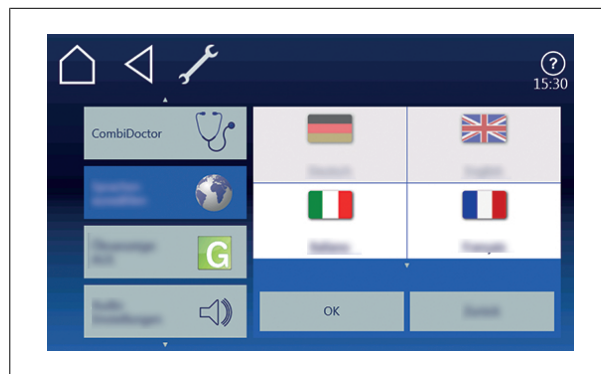

2. Select or deselect the language by tapping on the fields with national flags.
↳ Selected languages are displayed.
3. Tap on "OK" button.
↳ Languages for language selection are preset and are available in the main menu.

4.5.7 Setting favourites

The window for *Settings for favourites* is used to select, which view of the operating field is shown after the unit has been started. This restricts the usable functions for the operator.

Requirement *Equipment functions* menu open

1. Tap on equipment settings field for favourites.
↳ The *Equipment settings* window is displayed.

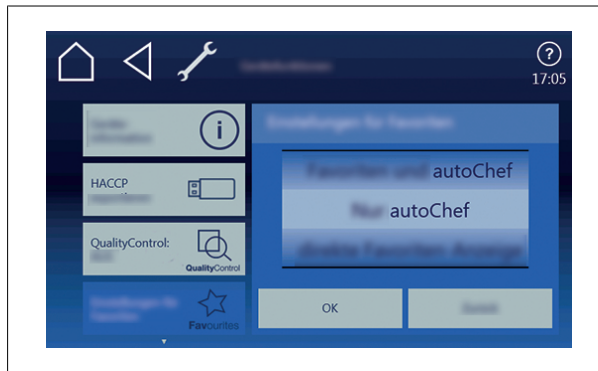

2. Place the roller on the desired display with wiping gesture.
3. Tap on "OK" button.
↳ *Equipment settings* window is closed.
↳ The favourites are set.

4.5.8 Activating and cancelling inhibit operation



The display can be locked either by tapping and holding the information bar or automatically after a specified time without touching the display. The time until the display is locked is set in the parameter level.

Activating inhibit operation

Requirement The "Operation locked ON" function is activated in the *Setting* menu

- Tap and hold the centre of the information bar for 3 seconds.
↳ The FlexiHelp button disappears and the Lock symbol appears in the information bar.
- ↳ The touchscreen is locked.

Cancelling inhibit operation

Requirement Touchscreen is locked

1. Tap on lock symbol.
↳ Keypad is opened.
2. Set password.
↳ The operating lock is unlocked by entering the password "369".
↳ The lock symbol and the keypad disappear. The *FlexiHelp* button becomes visible in the information bar and the touchscreen is enabled.

4.5.9 Setting the background lighting

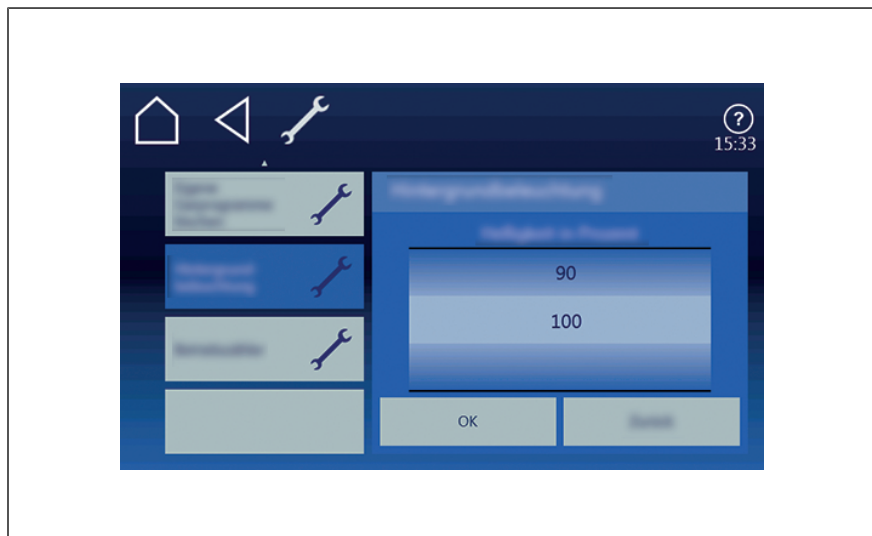

Image: Setting the brightness

Requirements The *Settings* menu is displayed

1. Tap the "Background lighting" field.
2. The menu for *Brightness in percent* is displayed.
↳ The roller displays the current value.
3. Using a wiping gesture, set the roller to the desired value.
4. Confirm with the "OK" button.
↳ The background lighting is set.

4.5.10 Setting the water filter maintenance

Requirement The *Settings* menu displayed

1. Tap on "Water filter maintenance" field.



2. The *Water filter maintenance* menu is displayed.
 - ↳ The entered value, which defines when to remind about the water filter maintenance, is displayed.
 - ↳ The amount of filtered water since the last filter change is displayed.
 - ↳ The value for the water filter maintenance can be entered on the keypad and confirmed with the "OK" field.

4.5.11 Possible settings in the parameter level

Requirement The *Settings* menu is displayed

1. Tap the "Settings parameters" field.
 - ↳ The *Settings parameters* menu is displayed.
2. Using a wiping gesture, set the rollers to the desired parameter.
 - ↳ The designation of the selected parameter is displayed.
3. Tap the "Read" button.
 - ↳ The current value of the selected parameter is displayed.
4. Delete the current value with the keypad.
5. Enter the new value with the keypad.
6. Tap the "Write" button.
 - ↳ The displayed value is adopted for this parameter.
- ↳ The parameter is changed.

Basic setting parameters

The unit is already preset, when it is delivered. The values in the following list can be adjusted at the parameter level.

Basic setting	Parameter s	Standard value	Adjustment range	Explanation
Screen lock				
Screen lock	662	0	0 = Deactivated 1 = Activated	Activate or deactivate the screen lock. The screen lock switches itself on after a certain time, if there have been no more inputs on the touchscreen.
Password	7	111	0 — 300	The password for the basic settings can be changed in this range.
Cooking modes				
Preselect steaming temperature	9	100	30 °C — 130 °C	Preset the temperature for steaming
Preselect Combisteam temperature	10	150	30 °C — 250 °C	Preset the temperature for Combisteam
Preselect Convection temperature	11	180	30 °C — 250 °C	Preset the temperature for Convection
Preselect regeneration temperature	12	130	30 °C — 180 °C	Preset the temperature for regeneration
Ready2Cook				
Ready2Cook active	607	1	0 = Not activated	Indicates whether the default setting is activated or not.
			1 = Activated	
Ready2Cook preheating temperature	4	15	0 — 30%	If the unit is fully loaded with a large mass (roasts, loaves of bread), increase the preheating temperature, so that the cooking zone temperature does not drop too suddenly.
Cooking				
SES: Use at the end of the cooking program	624	1	0 = Deactivated 1 = Activated	Default setting for Steam Exhaust System if new cooking programs are being created
Query message: Restart after interruption of cooking program	697	0	0 = No query 1 = Query only with AutoChef 2 = Query always activated	Setting for behaviour after interruption of the cooking program
Adopt changes after end of cooking program	696	0	0 = Do not adopt 1 = Adopt	Automatically save changes made at the end of a cooking program.

4.5.12 Importing video

Requirement WMV format
Data size <50 MB

1. Create the *VideosCustom* directory on a USB flash drive.
2. Save the desired video in this directory.
↳ USB flash drive prepared.
3. Insert USB flash drive into the multiport.
4. Open *Equipment functions* menu.
5. Open *Settings* menu.
6. Select *Import videos* menu.

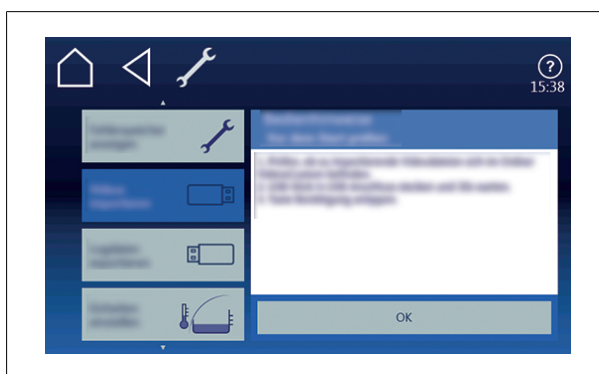

7. Follow the operating instructions.
↳ Video imported.

4.5.13 Importing images

Requirement PNG format
Image size 249x111 Pixel
Data size <50 MB

1. Create the directory *autoChefImages* on a USB flash drive.
2. Save the desired image in this directory.
↳ USB flash drive prepared.
3. Insert USB flash drive into the multiport.
4. Open *Equipment functions* menu .
5. Open *Settings* menu.
6. Select menu *Additional Content*.
7. Follow the operating instructions.
↳ Image imported.

4.5.14 Importing recipes



When converting into a HTML format, the text and graphics must be separate. For example in Microsoft Word, the text is saved under file type with the "Web page, filtered" storage filter. Before importing, make sure that the file type ends with "html".

Requirements HTML format

Data size < 50 MB

1. Create the directory *FCBrowserFiles* on a USB flash drive.
 2. Save the desired recipe in this directory.
 - ↳ USB flash drive prepared.
 3. Insert the USB flash drive into the MultiPort.
 4. Open the *Equipment functions* menu.
 5. Open the *Settings* menu.
 6. Select the *Import recipe* menu.
 7. Follow the operating instructions.
- ↳ Recipe imported.

4.6 Basic functions

4.6.1 Setting the cooking temperature

ATTENTION
Increased wear

Continuous use of the unit with cooking temperatures above 250 °C will result in increased wear.



The temperature range differs, depending on the cooking mode. At a cooking temperature outside the allowed temperature range, the display turns red.

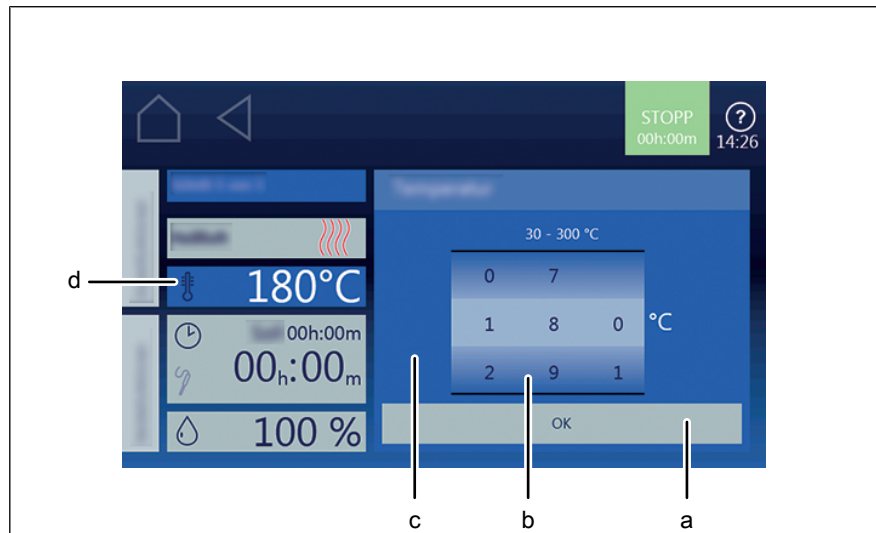

Image: *Cooking temperature setting window*

- | | | | |
|---|---------------------|---|-------------------|
| a | Confirmation button | c | Setting window |
| b | Rollers | d | Temperature field |

Requirement Cooking program selected

1. Tap the *Cooking temperature* field.
 - ↳ The *Setting* window is displayed.
 2. Tap the *Temperature* field.
 3. Using a wiping gesture, set the rollers to the desired value.
 - ↳ Wipe up / down to increase / decrease the cooking temperature.
 4. Tap the *Confirm* button.
 - ↳ The *Setting* window closes.
 - ↳ The *Cooking mode* window displays the set cooking temperature.
- ↳ The cooking temperature is set.

4.6.2 Setting the cooking time and continuous operation

Setting cooking time

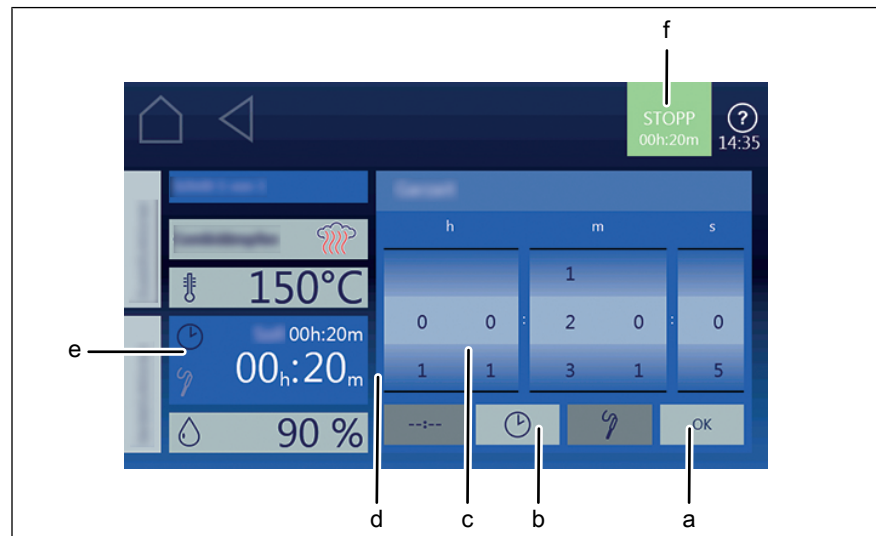

Image: Cooking time setting

- | | | | |
|---|---------------------|---|--------------------|
| a | OK button | d | Setting window |
| b | Cooking time button | e | Cooking time field |
| c | Rollers | f | Start button |

Requirement Cooking program selected

1. Tap on *Cooking time* field.
↳ The *Setting* window is displayed.
2. Tap on *Cooking time* button.
3. Set the rollers to the desired value with wiping gesture.
↳ Up or down, the cooking time is increased or decreased.
4. Tap on *OK* button.
↳ The *Setting* window is closed.
↳ The *Cooking mode window* displays the set cooking time.
↳ The cooking time is set.

Setting continuous operation

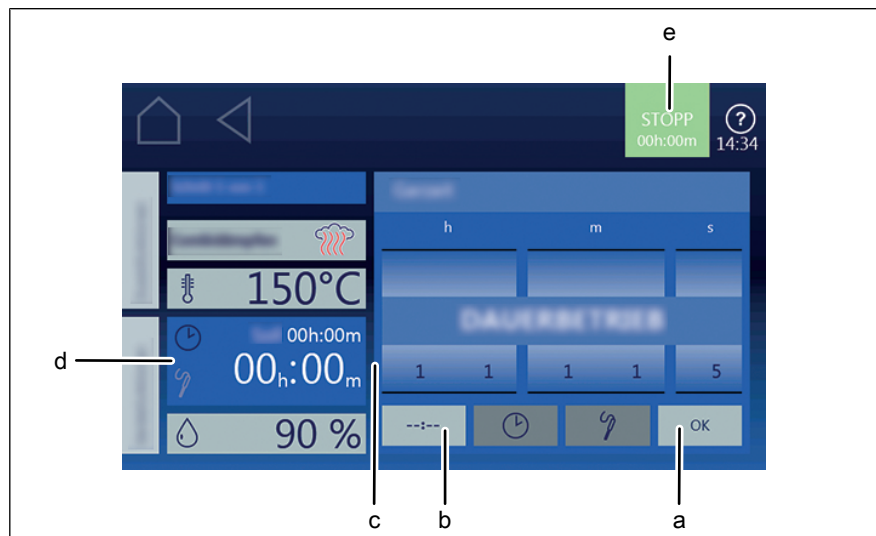

Image: Setting the cooking time to continuous operation

- | | | | |
|---|-----------------------------|---|--------------------|
| a | OK button | d | Cooking time field |
| b | Continuous operation button | e | Start button |
| c | Setting window | | |

Requirement Cooking program selected

1. Tap on *Cooking time* field.
 - ↳ The *Setting* window is displayed.
 2. Tap on *Continuous operation* button.
 3. Tap on *OK* button.
 - ↳ The *Setting* window is closed.
 - ↳ The *Cooking mode window* displays the set cooking time.
- ↳ The cooking time is set to continuous operation and ends after 24 hours.



A cooking step, which is running in continuous operation, can be converted to Remaining time.

4.6.3 Using start-time preselection

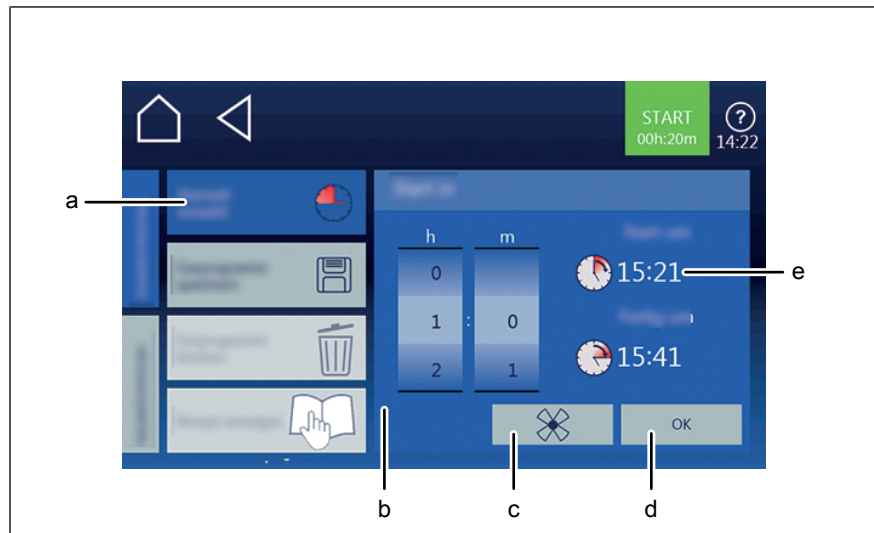

Image: Change start time preselection setting window

- a *Start time preselection field*
- b *Start time preselection window*
- c *Fan button*
- d *Confirmation button*
- e *Start time field*

Requirement Cooking program selected

Auxiliary functions menu open

1. Tap on the *Start-time preselection* field.
2. Using a wiping gesture, set the rollers to the desired value.
 - ↳ Swipe upwards or downwards.
 - ↳ The start time is set in minutes and seconds.
3. Tap on the *OK* button.
 - ↳ The *Start-time preselection* window displays the set start time.
 - ↳ The beginning and end of the start time is displayed in real time.
 - ↳ The start-time preselection is set as time-controlled.

4.6.4 Setting the core temperature



Further notes about working with the core temperature sensor can be found under Using the core temperature sensor.

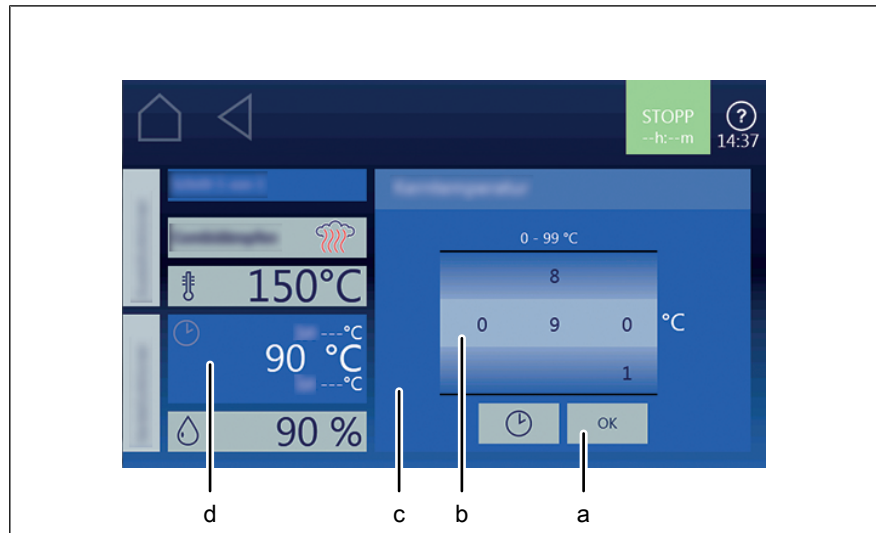

Image: Core temperature setting window

- | | | | |
|---|---------------------|---|------------------------|
| a | Confirmation button | c | Setting window |
| b | Roller Temperature | d | Core temperature field |

Requirement Cooking program selected
Cooking time set

1. Tap on *Cooking time* field.
 - ↳ The *cooking time* setting window is displayed.
2. Tap on *Core temperature* field.
 - ↳ The *Core temperature* setting window is displayed.
3. Set the rollers to the desired value with wiping gesture.
 - ↳ Wipe up or down, core temperature is increased or decreased.
4. Tap on *Confirmation* button.
 - ↳ The *Setting* window is closed.
 - ↳ The *Cooking time* field changes to the *Core temperature* field.

4.6.5 Setting the fan speed and direction of rotation

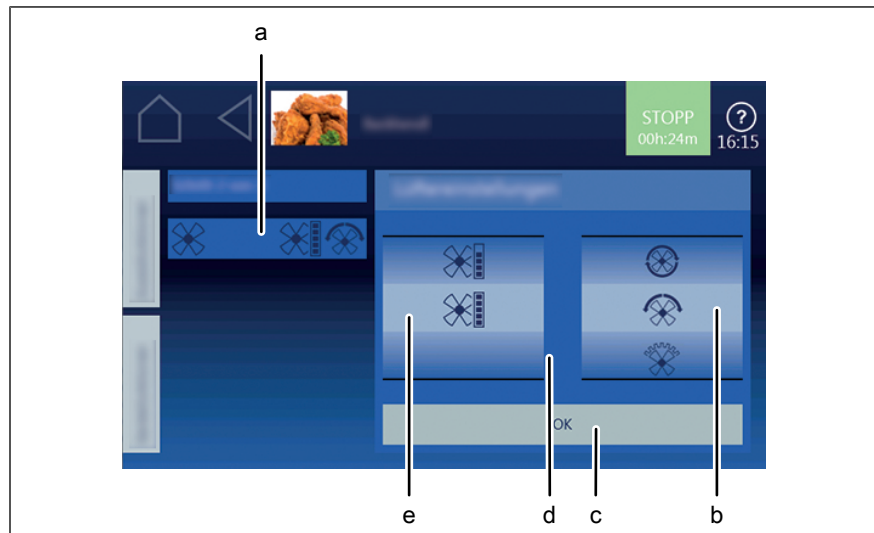

Image: Fan speed and fan rotation direction setting

- | | | | |
|---|-------------------------------|---|------------------|
| a | Fan setting field | d | Setting window |
| b | Roller Fan rotation direction | e | Roller Fan speed |
| c | OK button | | |

Requirement Cooking program selected

1. Tap on *Fan setting* field.
↳ The Setting window opens.
2. Set roller *fan speed* to the desired value with wiping gesture.
3. Set the roller *fan rotation direction* to the desired value with wiping gesture.
4. Tap on *OK* button.
↳ Fan speed and fan rotation direction is set.

4.6.6 Using Perfection (regeneration)

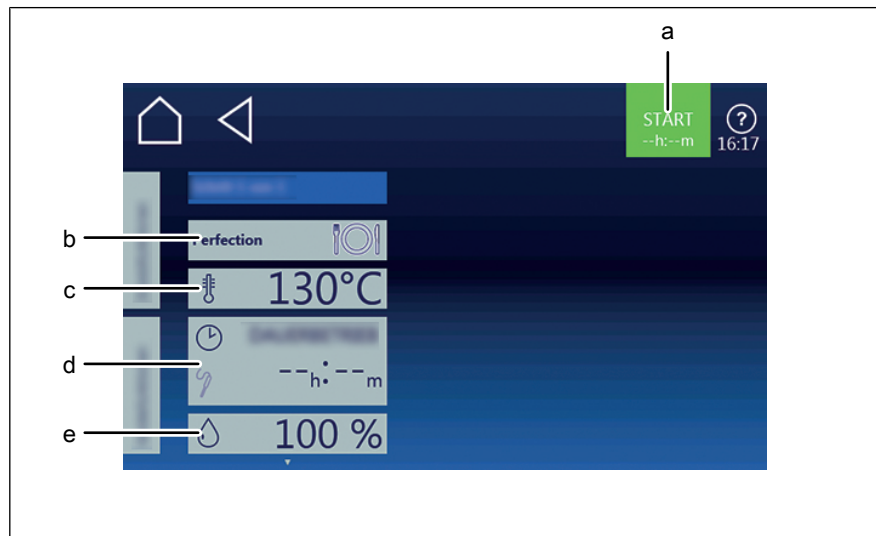

Image: Perfection cooking mode setting window

- | | |
|-----------------------------|-----------------------------|
| a "Start" button | d <i>Cooking time</i> field |
| b <i>Cooking mode</i> field | e <i>Moisture</i> field |
| c <i>Temperature</i> field | |

Starting Perfection

Requirements Food to be cooked is on the insert in the rack

Door closed

Manual cooking menu displayed

1. Tap the *Perfection* cooking mode field.
 - ↳ The *Cooking mode* window is displayed.
 2. Configure the settings.
 - ↳ The *Cooking mode* window shows the configured settings.
 3. Tap the "Start" button in the information bar.
 - ↳ The unit heats up.
 - ↳ The "Start" button is replaced with the "Stop" button.
 - ↳ The cooking time is updated in the *Cooking mode* window.
- ↳ Perfection is started.

Ending Perfection

Requirements Perfection started

Cooking time has not elapsed

1. Tap the "Stop" button in the information bar.

or

2. Wait for the cooking time to end.
 - ↳ The heating of the unit is ended.
 - ↳ The "Stop" button is replaced with the "Start" button.
 - ↳ The cooking time is reset.
- ↳ Perfection is ended.

4.6.7 Using PerfectHold

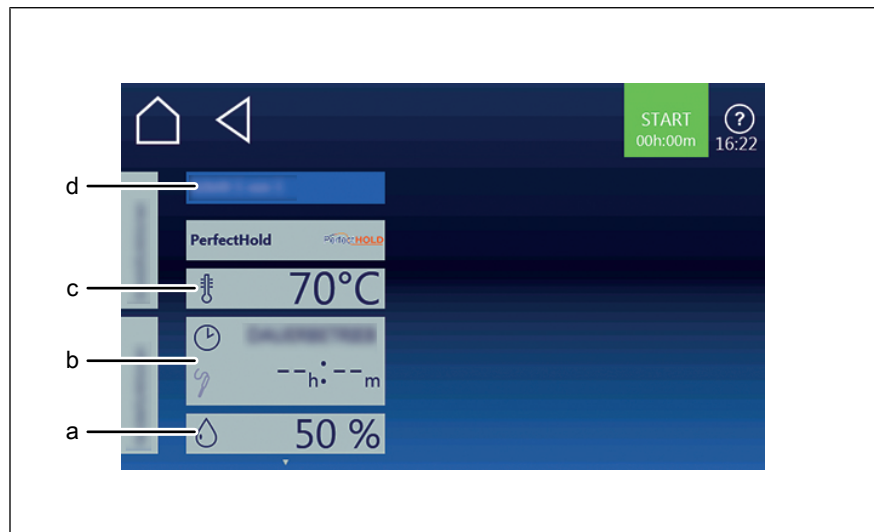

Image: Setting window PerfectHOLD

- | | | | |
|---|--------------------|---|-------------------|
| a | Moisture button | c | Temperature field |
| b | Cooking time field | d | Setting window |

Requirements Cooking program ended
Manual cooking menu open
Extended cooking function selected

1. Tap the *Temperature* field.
2. Using a wiping gesture, set the rollers to the desired value.
3. Tap the *Confirm* button.
 - ↳ The *Settings* window is closed.
4. Tap the *Cooking time* field.
 - ↳ The *Settings* window is displayed.
5. Tap the *Cooking time* button.
6. Using a wiping gesture, set the rollers to the desired value.
 - ↳ Wipe up / down to increase / decrease the cooking time.
7. Tap the *Confirm* button.
 - ↳ The *Settings* window is closed.
 - ↳ The *Cooking mode* window shows the set cooking time.
- ↳ PerfectHOLD is set as time-controlled.

4.6.8 Setting Ready2Cook

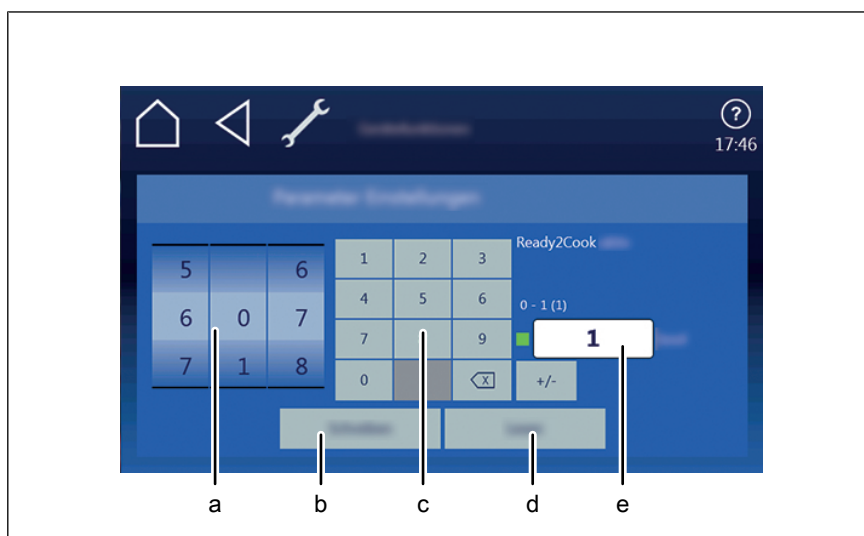

Image: Parameters window for "Ready2Cook" settings

- | | | | |
|---|---------------|---|-------------|
| a | Rollers | d | Read button |
| b | Write button | e | Display |
| c | Keypad button | | |

Requirement *Equipment function* menu open

1. Tap on "*Equipment settings*" field field.
 2. Set PIN 111 and confirm.
 3. Tap on *Parameter settings* field.
 - ↳ The *Parameter Settings* menu is displayed.
 4. Set the rollers to the desired value with wiping gesture.
 - ↳ The name of the selected parameter is displayed.
 5. Tap on *Read* button.
 - ↳ The current value is displayed.
 - ↳ Switch the function on or off if necessary.
 6. Delete current value using the keypad.
 7. Set new value using the keypad.
 8. Tap on *Write* button.
 - ↳ The displayed value is accepted.
- ↳ *Ready2Cook* function is set.

4.6.9 Using Steam Exhaust System (SES)



Steam Exhaust System (SES) automatically sucks the steam out of the cooking zone.

It is switched on as standard and can be switched off for individual programs.

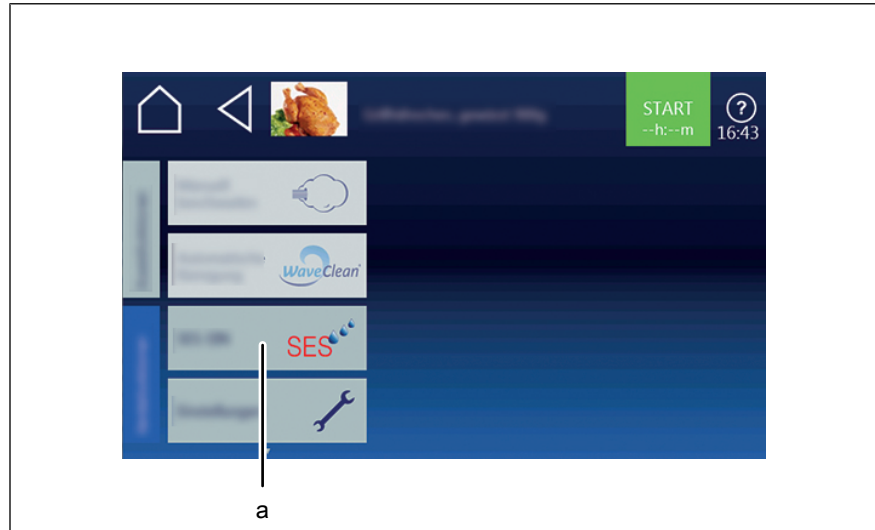

Image: Steam Exhaust System (SES) selection window

a *Steam Exhaust System* field

Requirement *ChefsHelp* info step created

1. Tap on the Auxiliary function.
2. Tap on the *SES* field.
 - ↳ The "ON" display changes automatically to "OFF" or vice versa.
 - ↳ The *SES* function is set.

4.6.10 Using RackControl2



During the cooking process, set parameters such as cooking time or core temperature can be altered for selected racks. The cooking process is not interrupted.

Parameters such as cooking zone humidity, cooking zone temperature and fan speed can be called up and set.

Changes only apply to the cooking program currently running, and they are not adopted as default settings.

Setting and starting RackControl2

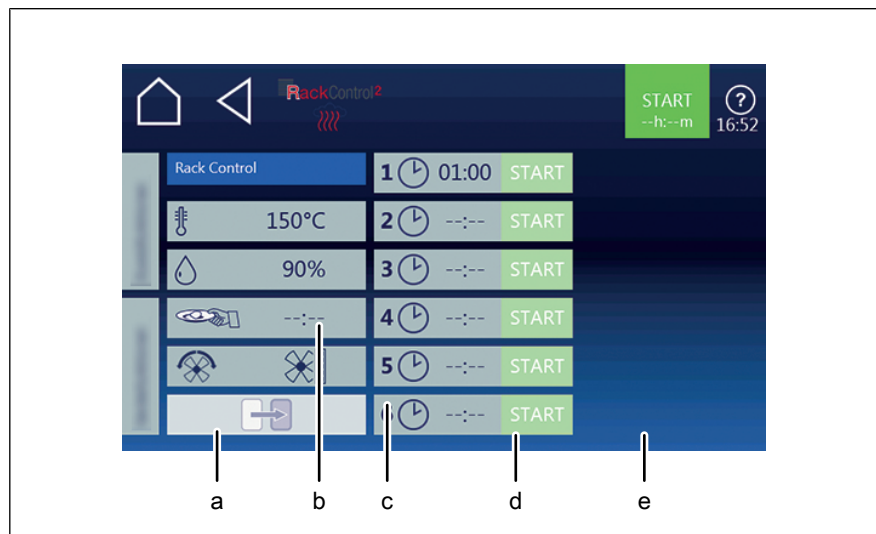

Image: Cooking time setting window RackControl2

- a *Equipment settings* field
- b *Slide-in unit* field
- c *Start time* window
- d *Start time* button
- e *Confirmation* button

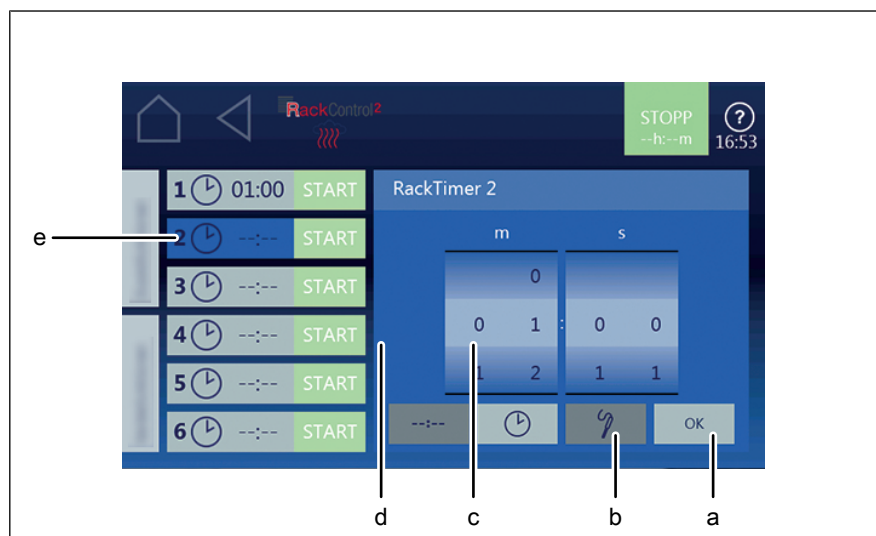

Image: Core temperature setting window RackControl2

- a *Confirmation* button
- b *Core temperature* button
- c *Rollers*
- d *Equipment settings* field
- e *Start time*field

Requirements *Manual cooking* field selected

1. Tap the *RackControl2* field.
2. Tap the *Cooking mode* field.
3. Tap the *Settings* field.
4. Open the next page with an upwards wiping gesture.
 - ↳ The next page with the *Fan setting* field is displayed.
5. Select the fan settings as required.

6. Select the desired rack.
 7. Configure the desired settings and confirm (see "Setting cooking time" and "Setting core temperature").
 - ↳ RackControl2 for selected rack is set.
 8. Configure the settings for further racks as required.
 9. Tap the "Start" button in the information bar.
 - ↳ The display changes to "Actual display".
 - ↳ The unit heats up.
 - ↳ The "Start" button is replaced with the "Stop" button.
- ↳ RackControl2 is started.

Ending RackControl2



Image: End window RackControl2 prematurely

a Stop button

b Setting window

Requirements RackControl2 started

Preheating temperature not reached

1. Tap the *RackControl2* window.
 - ↳ The last *Settings* display is shown.
 2. Open the next page with an upwards wiping gesture.
 3. Tap the *Continue* field.
 - ↳ Preheating is interrupted.
- ↳ RackControl2 starts with the actual temperature.

4.6.11 Setting Time2Serve



The cooking time can be set for up to 23 hours and 59 minutes in 1-minute increments.

Continuous operation is stopped automatically after 23 hours and 59 minutes.

The hours and minutes appear in the display.

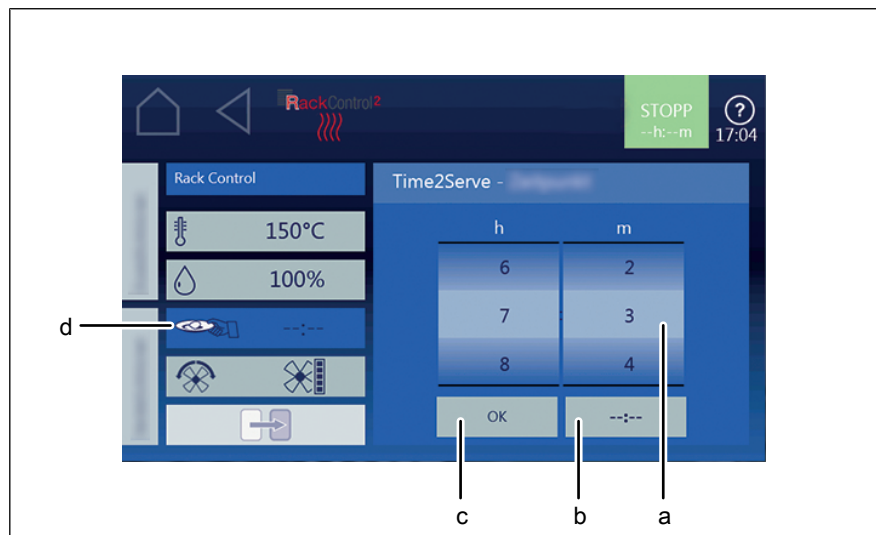

Image: Cooking time setting window Time2Serve

- a Rollers
- b *Continuous operation* button
- c *OK* button
- d *Time2Serve* field

1. Tap on *RackControl2* field.
2. Tap on *Cooking mode* field.
3. Tap on *Time2Serve* field.
4. Set the desired time with wiping gesture.
 - ↳ Time2Serve is set.
5. Make settings for RackTimer and confirm (see " using RackControl2 ").
 - ↳ RackControl2 is set for selected slide-in unit.
6. If necessary, make settings for additional racks.
7. Tap on "Start" button in the information bar.
 - ↳ The display changes to "actual display".
 - ↳ Unit heats up.
 - ↳ "Start" button is replaced by "Stop" button.
- ↳ Time2Serve has started.
- ↳ RackControl2 has started.

4.6.12 Using FamilyMix

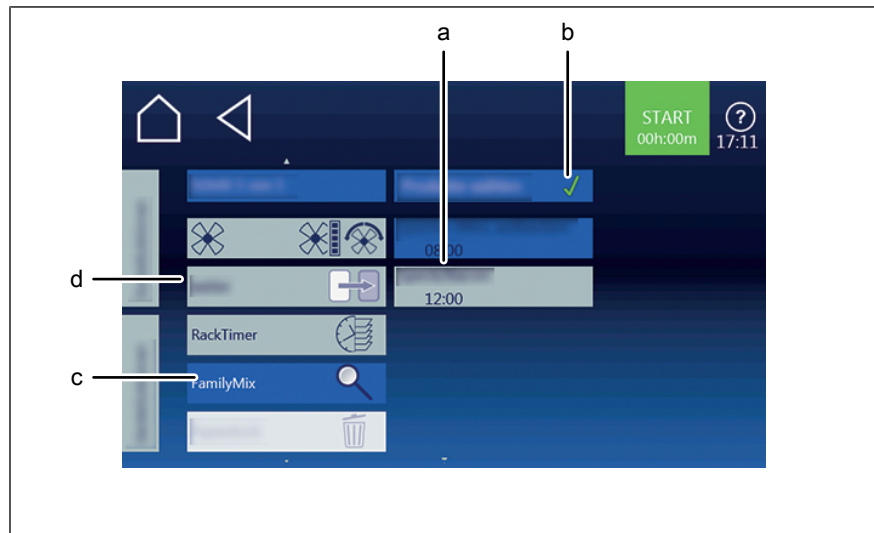

Image: FamilyMix selection window

- | | | | |
|---|------------------------|---|--------------------------|
| a | Product overview field | c | FamilyMix field |
| b | Product field | d | Equipment settings field |

Requirements *Manual cooking* field selected

Cooking program loaded

1. Tap the *Settings* field.
2. Tap the *FamilyMix* field.
3. Tap the *Product overview* field and select the product.
 - ↳ Tap the *Product* field: Product is selected.
 - ↳ Tap the *Product* field again: Product selection is cancelled.
4. Tap the "Start" button.
 - ↳ The display changes to "Ready2Cook".
 - ↳ The unit heats up.
 - ↳ The "Start" button is replaced with the "Stop" button.
5. Wait for the cooking time to end.
 - ↳ The heating of the unit is ended.
 - ↳ The "Stop" button is replaced with the "Start" button.
 - ↳ The cooking time is reset.
 - ↳ The *FamilyMix* function is set.

4.6.13 Using the Continue cooking function



If products with different preset cooking times are selected, the cooking time for selected products can be individually extended.



The *Continue cooking* function can be set in 1-minute increments up to a maximum of 5 minutes.

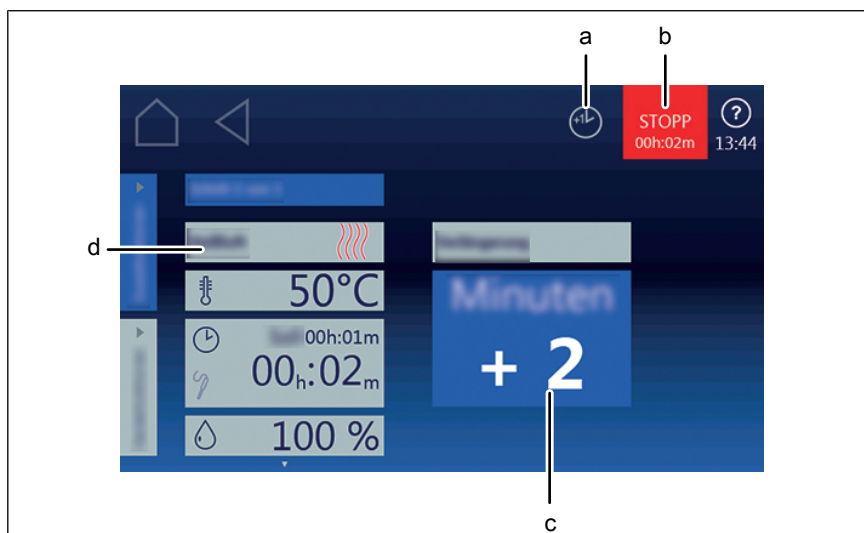

Image: Cooking time extension selection window

- | | | | |
|---|---------------|---|--------------------------|
| a | Simmer button | c | Simmer field |
| b | Stop button | d | Equipment settings field |

Requirements Cooking program selected
RackTimer function set

1. Tap the "Start" button.
 - ↳ The unit heats up.
 - ↳ The cooking program starts.
 - ↳ The "Start" button is replaced with the "Stop" button.
 2. Press the "Stop" button.
 - ↳ The cooking program is interrupted.
 - ↳ The "Continue cooking" button appears in the information bar.
 3. Tap the "Continue cooking" button.
 4. Set the desired time for Continue cooking.
 - ↳ The cooking time is increased in 1-minute increments.
 - ↳ The altered cooking time only applies to the current cooking program.
 - ↳ It does not change the saved cooking program.
 - ↳ The *Continue cooking* function is set.
 5. Tap the "Start" button.
 - ↳ The cooking program starts.
 - ↳ The cooking time is extended by the desired time.
- ↳ The *Continue cooking* function is performed.

4.6.14 Setting manual humidification



Image: Manual humidification setting window

- | | | | |
|---|--------------------------|---|-----------------------------|
| a | Fan setting field | c | Temperature field |
| b | Amount of moisture field | d | Manual humidification field |

Requirement The cooking program is running

1. Tap on the *Equipment functions* field.
↳ The *Equipment functions* menu is open.
2. Tap on the *Manual humidification* field.
↳ The *Manual humidification* menu is open.
3. Using a wiping gesture, set the rollers to the desired value.
↳ Upwards or downwards, cooking temperature is increased or reduced.
4. Tap on the *OK* button.
↳ The *Setting* window is closed.
5. Tap on the *Target injection quantity* field.
↳ The *Setting* window is displayed.
6. Using a wiping gesture, set the rollers to the desired value.
↳ Upwards or downwards, injection quantity is increased or reduced.
7. Tap on the *Confirmation* button.
↳ The *Setting* window is closed.
↳ Manual humidification is set.

4.6.15 Setting the rest stage



The *Insert rest stage* function is possible at any time.
Without saving, the stage only applies to the current cooking program.

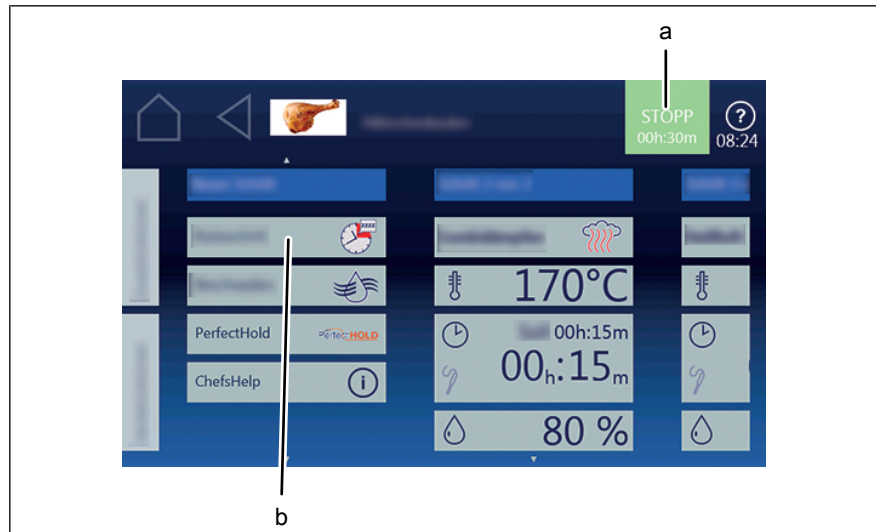

Image: *Insert rest step* window

a Start button

b Rest step field

Requirements *Automatic cooking* menu open
Cooking program selected

1. Select the *New step* function.
2. Tap the *Rest stage* field.
 - ↳ The *Manual cooking* menu appears.
3. Configure the settings.
 - ↳ Set the cooking mode.
 - ↳ Set the temperature.
 - ↳ Set the time.
 - ↳ Set the moisture.
4. Tap the "Start" button.
 - ↳ *Rest stage* is added to the current program.
 - ↳ *Rest stage* is not saved in the cooking program.
5. Save the cooking program.
 - ↳ *Rest stage* is saved in the cooking program.

4.6.16 Using QualityControl



QualityControl is a cooking time optimisation function, which adjusts the temperature automatically. It optimises the preheating process.

It is switched on as standard and can be switched off for individual programs.



The particular setting applies to all cooking programs until it is changed.

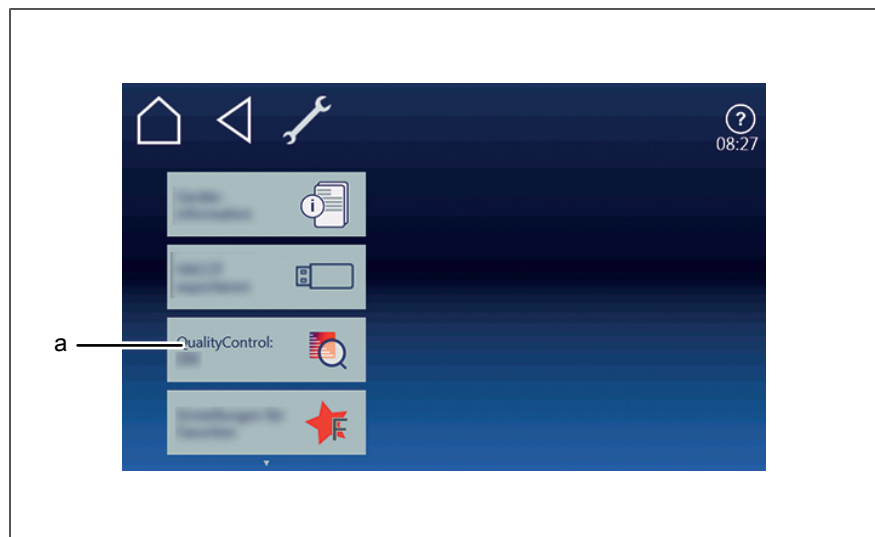

Image: QualityControl selection window

a *QualityControl* field

Requirement *Equipment functions* menu open

1. Tap on "Equipment settings" field.
2. Set PIN *111* and confirm.
↳ *QualityControl* field is displayed.
3. Switch the function on or off if necessary.
4. Tap on *QualityControl* field.
↳ The *ON* display automatically changes to *OFF* and vice versa.
↳ *QualityControl* function is set.

4.6.17 Using low-temperature cooking

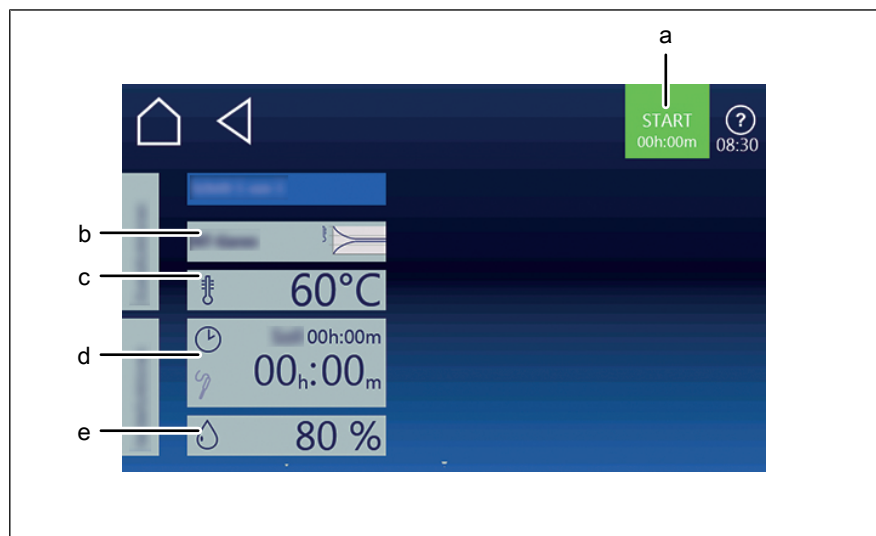

Image: *LT Cooking mode setting window*

- | | |
|---|-----------------------------|
| a "Start" button | d <i>Cooking time</i> field |
| b <i>Cooking mode</i> field | e <i>Moisture</i> field |
| c <i>Cooking temperature difference</i> field | |

Starting low-temperature cooking

Requirement Food being cooked on tray in the slide-in unit

Core temperature sensor set

Door closed

Manual cooking menu displayed

1. Tap on "LT cooking" Cooking mode field.
 - ↳ The "Cooking mode" window is displayed.
 2. Make settings.
 - ↳ The "Cooking mode" window displays the settings made.
 3. Tap on "Start" button in the information bar.
 - ↳ Unit heats up.
 - ↳ "Start" button is replaced by "Stop" button.
 - ↳ Cooking time is updated in the "Cooking mode window" window.
- ↳ LT cooking has started.

Ending low-temperature cooking

Requirements Low-temperature cooking started
Cooking time has not elapsed

1. Tap the "Stop" button in the information bar.
- or
2. Wait for the cooking time to end.
 - ↳ The heating of the unit is ended.
 - ↳ The "Stop" button is replaced with the "Start" button.
 - ↳ The cooking time is reset.
- ↳ Low-temperature cooking is ended.

4.6.18 Using the barcode scanner

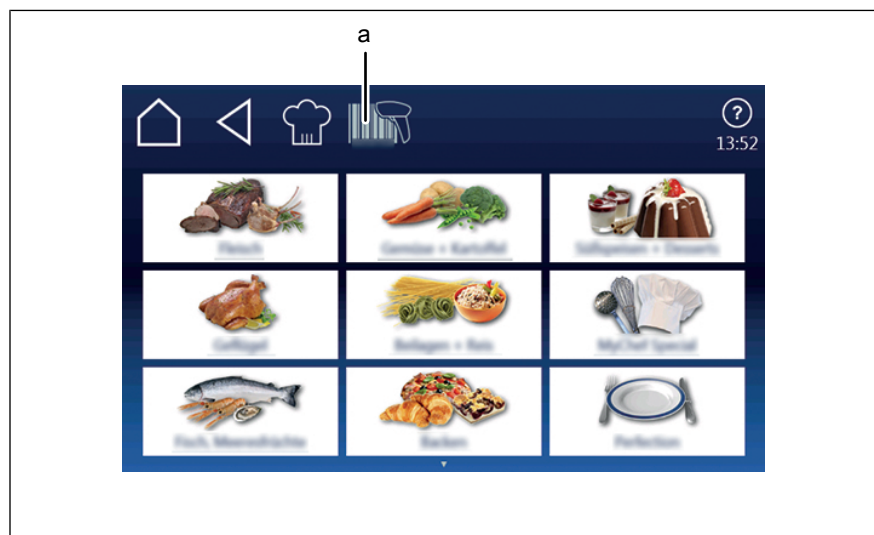

Image: *Barcode scanner selection window*

a *Barcode scanner* button

Requirement Barcode scanner connected

1. Tap on *Barcode scanner* button.
 2. Read barcode.
 - ↳ Product is selected.
 - ↳ Cooking program is loaded.
- ↳ *Barcode scanner* function is applied.

4.6.19 Inserting and removing a USB flash drive

Inserting a USB flash drive

Requirement USB flash drive with a minimum of 2 GB and maximum of 32 GB available storage capacity (not included with delivery)
USB flash drive not write-protected

→ Insert the USB flash drive.

↳ The USB flash drive is ready after at most 20 seconds.

Removing the USB flash drive

Requirement Exporting or importing of data completed

→ Remove the USB flash drive.

4.6.20 Preparing a USB flash drive for importing and exporting

Requirement USB flash drive is formatted
USB flash drive is not write-protected

1. Create folder structure for importing and exporting.
 2. Create "autoChefImages" folder name.
↳ Data exchange of photos in PNG format, resolution 249x111 pixels.
 3. Create "FCBrowserFiles" folder name.
↳ Data exchange of texts in HTML format.
 4. Create "FCImport" folder name.
↳ Data exchange of Cookbooks.
 5. Create "MMIContent" folder name.
↳ Import data exchange of additional content.
 6. Create "MMiUpdate" folder name.
↳ Data exchange of update files.
- ↳ Once the folder structure has been completed, the USB flash drive is ready for use.

4.6.21 Exporting the HACCP log

Requirement USB flash drive inserted
Registered under unit settings with password

1. Tap on "Export HACCP" field.



2. Select period of the logs.
3. Tap on *OK* button.
↳ The *operating instructions* window is opened.
4. Tap on *OK* button.
↳ HACCP protocol is exported to the USB flash drive.
↳ *OK* window is opened.
5. Tap on *Confirmation* button.
↳ *Confirmation* window is closed.



The HACCP log can also be transferred via a kitchen management system.

4.7 Using the core temperature sensor



WARNING

Risk of injury from a bursting core temperature sensor

- The core temperature sensor can burst as the result of overheating of the measuring tip.
 - Never heat a core temperature sensor with an open flame or other heat source.
-



CAUTION

Risk of burns from hot surfaces

- Grip the core temperature sensor by the handle, remove it from the food being cooked and put it carefully into the holder.
 - Protect arms and hands by wearing suitable protective gloves.
-

ATTENTION

Risk of property damage from improper handling of the core temperature sensor

- Do not let the integrated core temperature sensor hang out of the unit.
- Before removing the food, grasp the core temperature probe by the handle and remove it from the food.



A core temperature measurement is always possible, if the core temperature sensor is inserted in the food being cooked. Also before or after a cooking process or during a time-controlled cooking step.



Measuring the core temperature is recommended for all types of cooking to achieve an optimal result.

4.7.1 Measuring with a 4-point core temperature sensor

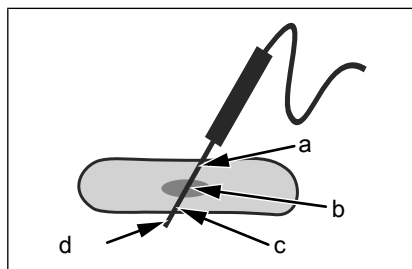

Image: Core temperature sensor with four measuring points

- Insert the core temperature sensor completely into the food being cooked.
- Insert the core temperature sensor into the thickest point of the food being cooked.
- If there is a bone in the food being cooked, insert the core temperature sensor close to the bone.
- When elongated pieces of food are being cooked, insert the core temperature sensor across the food to avoid a hole in the centre of the slice.
- When cooking poultry, insert the core temperature sensor into the inside of the leg.

4.7.2 Measuring the core temperature when cooking frozen food

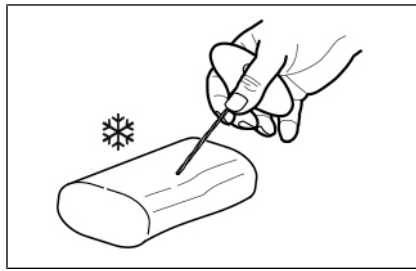
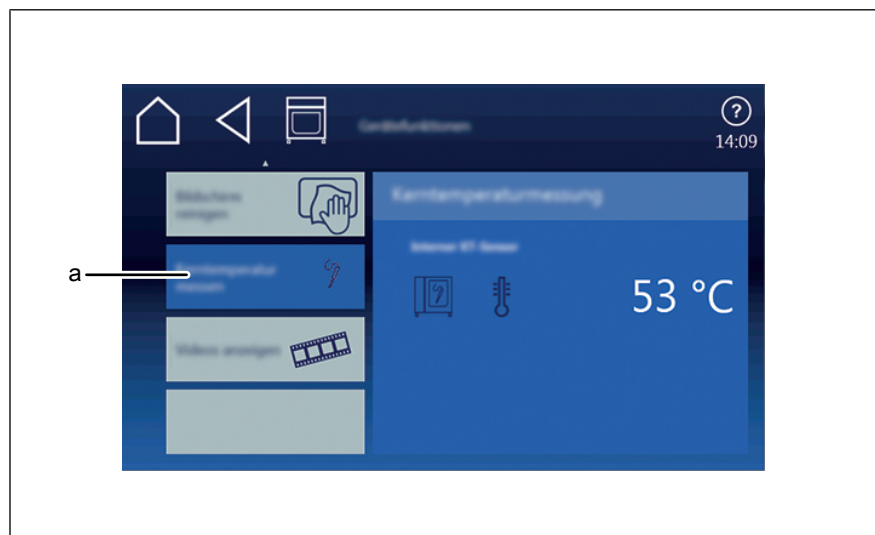

Image: Drilling a hole with a hand drill

1. Use a hand drill to make a hole for inserting the sensor.
2. Place the food to be cooked on the baking sheet or into the cooking pan.
3. Place the cooking sheet or cooking pan into the unit.
4. Insert the core temperature sensor into the food being cooked.

4.7.3 Core temperature display with time-controlled cooking process



a Core temperature button

b Core temperature display

Requirement Core temperature sensor in the food being cooked
Time-controlled cooking process is running

1. Tap the *Core temperature* button in the cooking step display.
↳ The current core temperature is displayed for 5 seconds.

4.7.4 Core temperature display outside the cooking process

Requirement Core temperature sensor in the food being cooked

1. Open *Equipment functions* menu.



2. On the second page, tap on "Measure core temperature" button.
↳ Core temperature is displayed.

4.8 Manual cooking

Cooking modes and other functions are available in the Manual cooking mode. Selecting one of these components automatically creates a single-step cooking program.

Settings such as Cooking mode, Cooking temperature and Cooking time are specified, and the cooking step is either started or saved.

4.8.1 Opening the Manual cooking menu

Requirement The unit is on
The main menu is displayed

- Tap the "Manual cooking" button.
↳ The *Manual cooking* menu is displayed.

4.8.2 Creating a cooking program step

Requirement Unit switched on
Manual cooking menu is displayed
Cooking mode selected

1. Tap on *Cooking temperature* field.
↳ The *Setting* window is displayed.



2. Set rollers to the desired value with wiping gesture.
3. Tap on *OK* button.
↳ The *Setting* window is closed.
4. Tap on *Cooking time* field.
↳ The *Setting* window is displayed.



5. Tap on *Continuous operation* button *Cooking time* button or *Core temperature* button.
6. Set rollers to the desired value with wiping gesture.
7. Tap on *OK* button.
↳ The *Setting* window is closed.
8. Tap on *Cooking zone humidity*.
↳ The *Setting* window is displayed.

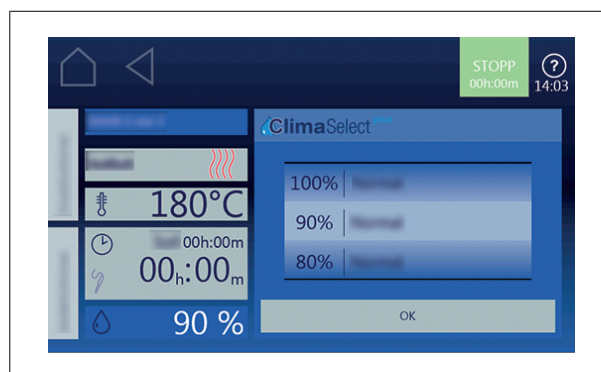

9. Set roller to the desired value with wiping gesture.
10. Tap on *OK* button.
↳ The *Setting* window is closed.
11. Change to the next page with wiping gesture and make further settings.

12. Tap on *Fan* field.

↳ The *Setting* window is displayed.

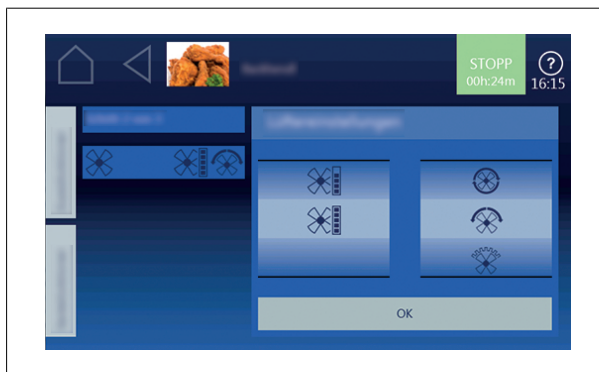

13. Set fan speed and direction of rotation.

14. Set rollers to the desired value with wiping gesture.

15. Tap on *OK* button.

↳ The *Setting* window is closed.

↳ Cooking program step can be started.

Tip The cooking mode can also be changed while entering the cooking step.

- Tap the *Cooking mode* field.
 - ⇒ Possible selections appear.
- Tap the cooking mode.
 - ⇒ The standard values of the selected cooking mode are displayed.
- Modify the values.
 - ⇒ Cooking mode for this cooking step is changed.

4.9 Creating and managing your own cooking programs

Cooking modes and other functions are available in the *Manual cooking* menu. Using these components, users can create their own programs.

ATTENTION

Risk of physical damage from data loss

Regularly save your own cooking programs on an external memory medium, for example a USB flash drive.

4.9.1 Creating a cooking program

Creating a Cooking program step

Requirement *Manual cooking* menu displayed

1. Tap on desired Cooking mode field.
 - ↳ The first step of the Cooking program is created.
 - ↳ The Cooking program step display shows "Step 1 of 1".
2. Adjust the desired settings for the first step.
 - ↳ The Cooking program has been created with the first step.

Adding the Cooking program step

1. The next page is opened with a wiping gesture.
 - ↳ Next page is displayed.

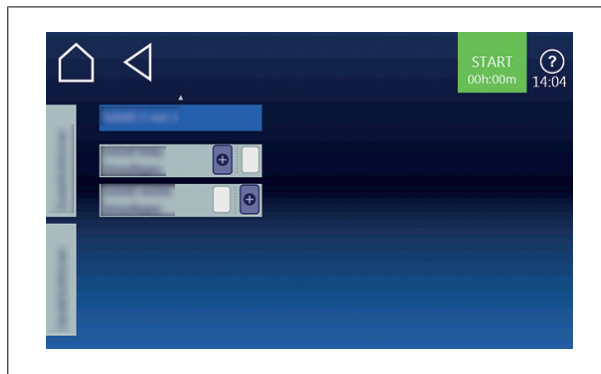

2. Tap on "Add prior step" field.
 - or
3. Add the "Add step after" field.
 - ↳ The "New Step" window opens.
4. Select the Cooking mode or function from the window by tapping.
 - ↳ Cooking program step display of the window shows the current position of the new step in the Cooking program.
5. Adjust the settings of the step.
 - ↳ New step is added.

Deleting a cooking program step



If a cooking program has only one step, it cannot be deleted.
The function is not active.

1. Select the step.
2. A wiping gesture upward opens the next page.

↳ The next page for the step is displayed.



3. Tap the "Delete step" field.

↳ The *Delete* window is displayed.

4. Tap the "Yes" button.

↳ This deletes the step.

↳ The positions of the remaining steps in the cooking program are updated.

↳ The step is deleted.

4.9.2 Saving the cooking program

ATTENTION

Risk of physical damage from data loss

Regularly save your own cooking programs on an external memory medium, for example a USB flash drive.



Cooking programs that have been created can be saved prior to starting or after completion of the cooking program.



To save a cooking program, at least one cooking program name and one category must be specified.

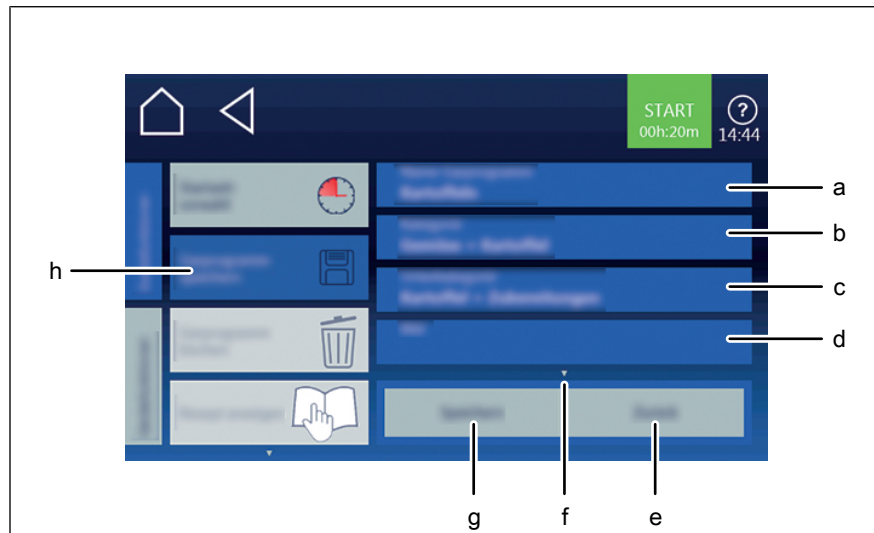

Image: Cooking program in the Save window

- | | |
|--------------------------------|--------------------------------|
| a "Cooking program name" field | e "Back" button |
| b "Category" field | f "next page" arrow symbol |
| c "Subcategory" field | g "Save" button |
| d "Screen" field | h "Save cooking program" field |

Requirement The Cooking program has been created and is displayed

1. Tap on *Auxiliary functions* tab.
 - ↳ *Tab* window is open.
 2. Tap on "Save cooking program" field.
 - ↳ *Save* window is open.
- ↳ Save after making the entries.

Saving the cooking program name

1. Tap on "Cooking program name" field.
 - ↳ *Keypad* menu is displayed.
2. Set the desired program name using the buttons.
3. Tap on *OK* button.
 - ↳ *Keypad* menu is closed.
 - ↳ Program name is displayed in the *Save* window.

Entering a category

1. Tap on "Category" field.
 - ↳ *Automatic cooking* menu is displayed.
2. Tap on field with the desired *Category*.
 - ↳ Category is set.
 - ↳ *Automatic cooking* menu is closed.
 - ↳ Category is displayed in the *Save* window.

Entering a subcategory (optional)

1. Tap the "Subcategory" field.
 - ↳ The *Subcategory* menu is displayed.
2. Tap the field with the desired *Subcategory*.
 - ↳ The subcategory is set.
 - ↳ The *Subcategory* menu closes.
 - ↳ The subcategory is displayed in the *Save* window.

Assigning an image (optional)

1. Tap the "Image" field.
 - ↳ The *Image* menu is displayed.
 - ↳ Images stored in the unit are displayed.
 2. Select image by tapping it.
 - ↳ The *Image* menu is closed.
 - ↳ The name of the image is displayed in the *Save* window.
- ↳ Selected image is assigned to the cooking program.



Preparation:

Create the directory autoChefImages on a USB flash drive.

Save image in PNG format, resolution 249x111 pixels in this folder.

3. Insert the USB flash drive.
 - ↳ The USB flash drive is ready after at most 20 seconds.
 4. Tap the "Image" field.
 - ↳ The *Image* menu is displayed.
 - ↳ Images stored in the unit are displayed.
 5. Tap the "Images on USB flash drive" button.
 - ↳ The images stored on the USB flash drive are displayed.
 6. Select image by tapping it.
 - ↳ The *Image* menu is closed.
 - ↳ Image is stored in the device.
 - ↳ The name of the image is displayed in the *Save* window.
- ↳ Selected image is stored in the unit and assigned to the cooking program.

Assigning a video (optional)

1. Tap the "Video" field.
 - ↳ The *Video* menu is displayed.
2. Select the video by tapping it.
3. Select the location to save the photo.
4. Tap the button for "Videos in unit" or "Videos on USB flash drive".
 - ↳ Video is selected.
 - ↳ The *Video* menu is closed.
 - ↳ The name of the video is displayed in the Save window.

Assigning a recipe (optional)

1. Tap the "Recipe" field.
 - ↳ The *Recipe* menu is displayed.
2. Tap the "Empty recipe" field.
3. Select the save location.
4. Tap the "Recipes in unit" button or the "Recipes on USB flash drive" button.
 - ↳ The recipe is set.
 - ↳ The *Recipe* menu closes.
 - ↳ The name of the recipe is displayed in the *Save* window.

Selecting favourites (optional)

1. Tap the "Show favourites" field.
 - ↳ The *Show favourites* menu is displayed.
2. Tap the "Yes" button or the "No" button.
 - ↳ Tapping Yes displays the cooking program in the Favourites menu.

Selecting characteristics of the food to be cooked (optional)

1. Tap the "Frozen food" field.
 - ↳ The *Frozen food* menu is displayed.
2. Tap the "Yes" button or the "No" button.
 - ↳ Tapping Yes selects the food to be cooked as a frozen food.

Assigning an identification (optional)

1. Tap the "Identification" field.
 - ↳ The *Identification* menu is displayed.
 2. Key in the barcode on the keypad.
- or
3. Scan with the barcode scanner.
 - ↳ Scan the barcode and assign to a cooking program or to food to be cooked.

Selecting QualityControl

1. Tap the "QualityControl" field.
 - ↳ The *QualityControl* menu is displayed.
 2. Tap the "No" button.
 - ↳ QualityControl is deactivated for the cooking program.
 3. Tap the "Yes" button.
 - ↳ Tapping Yes sets the cooking program for a minimal amount of food to be cooked.
- ↳ QualityControl automatically adjusts the cooking time for a larger charge.

4.9.3 Exporting a cooking program



Previously exported cooking programs on the USB flash drive will be overwritten.

Requirement Cooking program open
 Cooking program saved
 USB flash drive inserted

1. Tap on *Auxiliary functions* tab.
 - ↳ *Tab* window is open.
2. Tap on "Export Cooking programs" field.
 - ↳ The *operating instructions* window is opened.



3. Read displayed operating instructions.
 4. Tap on *OK* button.
 - ↳ The Cooking program is exported to the USB flash drive.
 - ↳ *OK* window is displayed.
 5. Tap on *OK* button.
 - ↳ *Auxiliary functions tab* window is closed.
- ↳ Cooking program is exported.

4.10 Automatic cooking (autoChef)

In the "Automatic cooking" mode, all cooking programs stored in the unit are available. The cooking program is selected in the *Automatic cooking* menu.

4.10.1 Opening the Automatic cooking menu

Requirement Unit switched on
Main menu displayed

→ Tap on "autoChef" button.

↳ *Automatic cooking* menu is displayed.

4.10.2 Finding and opening a cooking program

Finding and opening cooking program via category

Cooking programs can be found in the *Automatic Cooking* menu via categories and subcategories.



Arrow symbols in a window always display the next or previous page. A wiping gesture upward or downward opens the corresponding window.

Requirement Unit switched on
Main menu is displayed

1. Tap on "autoChef" button.

↳ *Automatic cooking* menu is displayed.

2. Tap on field with the desired category.

↳ The subcategory menu is displayed.

3. Tap on field with the desired subcategory.

↳ Recipe menu with all recipes in the subcategory are displayed.

4. Tap on field with the desired recipe.

↳ Cooking program is selected and loaded.

↳ Cooking program steps are displayed.

↳ Cooking program is open.

Requirement Unit switched on
Main menu is displayed

1. Tap on "autoChef" button.

↳ The category menu is displayed.

2. Tap on "autoChef" button in the information bar.

↳ The *autoChef* window is displayed.

3. Tap on *Find cooking program* field.

↳ The *Find* window is displayed.



4. Set the letters of the name you are searching for using the keypad.
 - ↳ A filtered list is displayed in the *Results* display.
 5. Tap on field with the name you are searching for.
 - ↳ Cooking program is selected and loaded.
 - ↳ Cooking program steps are displayed.
- ↳ Cooking program is open.

4.10.3 Starting the cooking program



The current step in the cooking program is highlighted. Upon completion, the following step automatically appears in the display.

Requirement Cooking program open

1. Tap the "START" button in the information bar.
 - ↳ The cooking program starts.
 - ↳ The "START" button in the information bar changes to the "STOPP" button.
 - ↳ The remaining cooking program time is displayed in the "STOPP" button.
- ↳ The cooking program is started.

4.10.4 Ending the cooking program

Requirement Cooking program started Cooking program time has not elapsed

1. Tap the "STOPP" button in the information bar.
- or
2. Wait for the cooking time to end.
 - ↳ Cooking program has ended.
 - ↳ The "STOPP" button in the information bar changes to the "START" button
- ↳ The cooking program has ended.



If the cooking zone door is not opened, the fan continues to run at a low speed at intervals. This achieves even cooking.



If the current cooking process is stopped manually, a window appears under certain circumstances with *Cooking program has been interrupted*.

You then have the opportunity to end or continue the cooking program.

4.10.5 Modifying the cooking program



Tabs available only within cooking programs or the cooking step display. Tapping the tabs provides faster access to their functions.



The current step in the cooking program is highlighted and can be modified. All settings of a step can be modified.



After the settings are made, the modified cooking program can be saved. The cooking program is overwritten if a new cooking program name is not specified.

Modifying a cooking program after the program has started

Requirement Cooking program started

Cooking program has not elapsed

1. Modify the settings for the current step.
 - ↳ The modifications to the step become active immediately.
 - ↳ The modifications to the step are displayed.
 2. Tap the "Continue" field.
 - ↳ The active step is being ended.
 - ↳ The next step is being started.
 - ↳ The steps advance in the *Settings* window.
- ↳ The cooking program is modified.

Modifying a cooking program before the program has started

Requirement Cooking program open

Cooking program not started

1. Modify various steps.
 2. Use a wiping gesture to reach the individual step to be modified.
 3. Modify the settings for the step.
 - ↳ The modifications of the step are displayed.
 - ↳ The cooking program can be started without being saved.
 - ↳ If the modifications are to be saved, continue with the next step.
 4. Tap the *green* tab.
 - ↳ The *Tab* window is open.
 5. Save the cooking program.
 - ↳ All modifications to the cooking program are saved.
- ↳ The saved cooking program is modified.

4.10.6 Deleting a cooking program

Requirement Cooking program open
Cooking program not started

1. Tap on *Auxiliary functions* field.
↳ *Tab* window is open.
2. Tap on "Delete Cooking program" field.
↳ *Delete* window is displayed.

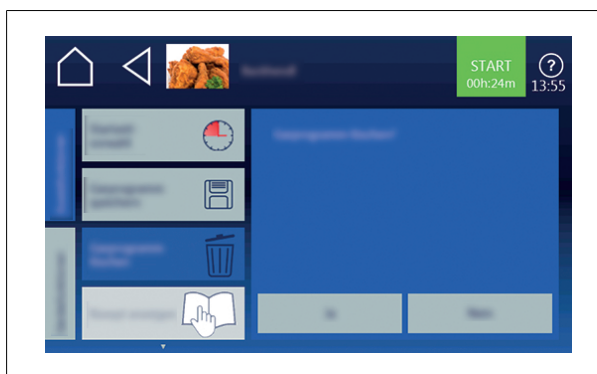

3. Tap on "Yes" button.
↳ Cooking program is deleted.
↳ *Confirmation* window is displayed.
4. Tap on *Confirmation* button.
↳ *Auxiliary functions* tab is closed.
↳ Cooking program is deleted.

4.10.7 Exporting and importing a cooking program

Exporting Cooking programs

When exporting, all the Cooking programs you have created in the Cookbook are exported.



Previously exported cooking programs on the USB flash drive will be overwritten.

Requirement USB flash drive inserted
Automatic cooking menu open
Self-created Cooking programs are saved in the Cookbook

1. Tap on "autoChef" button in the information bar.
↳ *autoChef* window is opened.
2. Tap on "Export Cooking programs" field.
↳ The *operating instructions* window is opened.
↳ Read displayed operating instructions.



3. Tap on *OK* button.
 - ↳ All self-created Cooking programs from the Cookbook are exported to the USB flash drive.
 - ↳ *Confirmation* window is displayed.
4. Tap on *OK* button.
 - ↳ Close *Confirmation* window.
 - ↳ Cooking programs are exported.

Importing Cooking programs

When importing, the Cookbook is supplemented with the new Cooking programs.



Existing cooking programs can be overwritten or the file names of the imported cooking programs can have a supplement added.

Requirement USB flash drive inserted
Automatic cooking menu open.

1. Tap on "autoChef" button in the information bar.
↳ *autoChef* window is opened.
2. Tap on "Import Cooking programs" field.
↳ The *operating instructions* window is opened.
↳ Read displayed operating instructions.



3. Tap on *Confirmation* button.
↳ All Cooking programs on the USB flash drive are imported into the Cookbook.
↳ *Operating instructions* window is displayed.
4. Tap on "OK" button.
↳ Cooking programs are imported.

4.11 VideoAssist

4.11.1 Watching a video

Requirement Videos saved on the unit.

1. Open the *Equipment function* menu.
2. Open the *Display videos* menu.

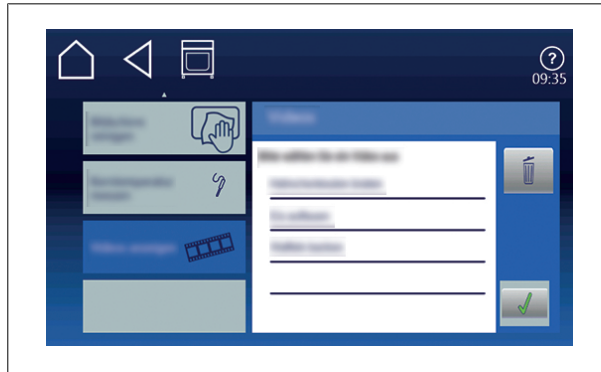

3. Select the video by tapping it.
 4. Tap the *Confirm* button.
- ↳ The video is played.

4.11.2 Deleting a video

Requirement The *Display videos* menu is open.

1. Tap the *Delete* field.
↳ The *Delete* field becomes dark.
2. Tap the videos to be deleted.
↳ The *Delete* symbol appears behind the designation of the video.
↳ If you tap again on the video, the selection deletes this video.

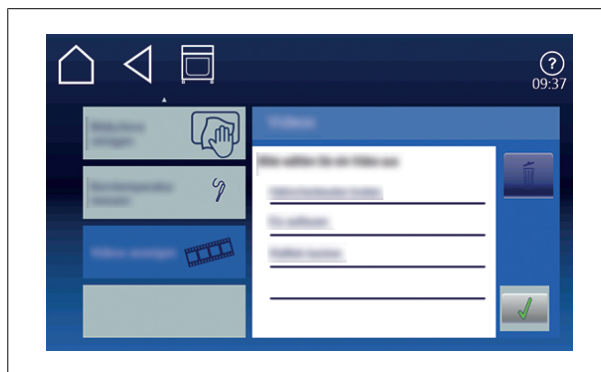

3. Touch the *Confirmation* field.
↳ The marked videos are deleted.

4.12 Pausing and finishing use

Switch off the unit during pauses and at end of use.

4.12.1 Perform a hygiene flush after an extended period of idleness

For reasons of hygiene, flush the water lines in the unit and on-site water lines before using the unit.

Period of idleness lasting more than 2 days

Requirements GN containers, baking trays and grates removed from the cooking zone

The cooking zone contains no food to be cooked

1. Rinse out the cooking zone thoroughly with clear water.
2. Run the unit in the Steaming mode for 7 minutes at 100 °C.

Idle period for more than 7 days

Requirements GN containers, baking trays and grates removed from the cooking zone

The cooking zone contains no food to be cooked

1. Rinse out the cooking zone thoroughly with clear water.
2. Run the unit in the Steaming mode for 1 hour at 100 °C.

5 Cleaning and caring for the unit



CAUTION

Risk of burns from hot surfaces

- Allow surfaces to cool prior to cleaning.

ATTENTION

Risk of physical damage from extremely abrupt cooling

- Do not cool shock the unit by cooling it abruptly.

ATTENTION

Risk of physical damage from improper cleaning

- Do not clean the unit with a high-pressure cleaner or water jet.



CAUTION

Risk of chemical burns from cleaning agent

- Follow the instructions of the cleaning agent manufacturer.
- Take appropriate protective measures when handling aggressive cleaning agents.

Cleaning traffic light and cleaning reminder

For units with automatic cleaning, a cleaning traffic light is displayed in the main menu in the "WaveClean" button.

Depending on the use and degree of soiling of the unit, the cleaning light changes the traffic light phase.

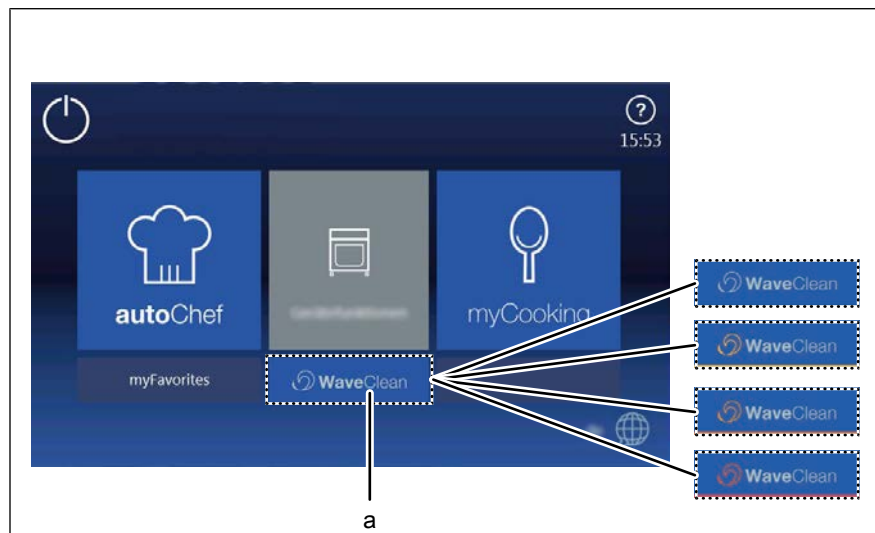

Image: Main menu

a "WaveClean" button with cleaning traffic light

From the red light phase, the unit displays a cleaning reminder. The unit can continue to be used, but if it is not cleaned, the cleaning reminder will appear more frequently.

Traffic light phase	Explanation
grey	Pollution level low
yellow	Pollution level medium
orange	Pollution level high
Red	Pollution limit reached 1. Warning level: Cleaning reminder is displayed each time the device is started 2. Warning level: Cleaning reminder is displayed after each end of cooking process 3. Warning level: Cleaning reminder is displayed after each end of cooking process and acoustic signal sounds

5.1 Preventing corrosion

- Keep the surfaces of the unit clean and with access to air.
- Remove lime, grease, starch and protein deposits from the surfaces of the unit.
- Remove salt accumulations.
- Only expose parts made from non-rusting steel to brief contact with highly acidic foods, spices, salts or the like.
- Avoid damaging the stainless steel surface with other metal items, such as for example steel spatulas or steel wire brushes.
- Avoid contact with iron and steel, such as for example steel wool and steel spatulas.
- Do not use bleaching or chlorine-containing cleaning agents.
- Clean the contact surfaces with water.

5.2 Remove rust spots

- Remove fresh rust spots immediately with a mild abrasive or fine sandpaper.
- Always remove rust spots completely.
- Expose treated areas to fresh air for at least 24 hours. During this time, do not allow any contact with greases, oils or foods so that a new protective layer can form.

5.3 Cleaning the housing

Requirement Unit switched off and cooled down

→ Clean the housing with warm water and commercially available washing-up liquid.

5.4 Cleaning the door handle, operating elements and control panel

ATTENTION

Risk of property damage from improper cleaning

- Do not clean the surface with highly abrasive or chemically aggressive cleaning agents.
 - Do not clean the surface with highly abrasive sponges.
-

Requirements Unit is disconnected

→ Clean the door handle, operating elements and control panel with a damp cloth and commercially available detergent.

5.5 Cleaning the touchscreen

ATTENTION

Risk of physical damage from improper cleaning

- Do not clean the touchscreen with highly abrasive or chemically aggressive cleaning agents.
 - Do not clean the touchscreen with highly abrasive sponges.
-



A cleaning time of 10 seconds is provided. The touchscreen cannot be operated during this time.

Requirement *Equipment function* menu displayed

1. Tap on "Clean touchscreen" field.
 - ↳ Touchscreen no longer reacts to tapping.
 - ↳ *Cleaning* window is displayed.
 - ↳ Cleaning time is updated.
 2. Clean touchscreen within 10 seconds.
 - ↳ *Cleaning* window is closed.
 - ↳ *Equipment function* menu is displayed.
- ↳ Touchscreen is cleaned.

5.6 Cleaning the door seal

ATTENTION

Risk of physical damage from improper cleaning

Animal fats in combination with high temperatures can damage the door seal very quickly if it is not maintained properly.

- Clean the door seal regularly.
- Do not use aggressive cleaners.



During automatic cleaning and semi-automatic cleaning, the outside surface of the door seal is not cleaned.

The door seal must be cleaned separately.



If the unit is used primarily for roasting, also clean the door seal during pauses in use.

→ When finished using the unit, clean the door seal with warm water and a commercially available detergent.

5.7 Cleaning the cooking zone door



CAUTION

Risk of burns from hot surfaces

- Allow surfaces to cool prior to cleaning.

ATTENTION

Risk of physical damage from improper cleaning of the surface

- Do not use abrasive cleaners or cloths.
- Do not use grill cleaners.

ATTENTION

Risk of property damage from improper cleaning

- Do not clean the surface with highly abrasive or chemically aggressive cleaning agents.
- Do not clean the surface with highly abrasive sponges.

5.7.1 Cleaning the door with hygienic glazing

→ Remove residual calcium deposits from the glass window with vinegar or citric acid.

5.8 Removing calcium deposits from the unit

Requirement Cooking zone temperature less than 40 °C
Cooking zone cleaned

1. Spray commercially available descaler into the cooking zone.
2. Allow to act for 30 minutes.
3. Rinse cooking zone thoroughly.
4. Examine the cooking zone for any remaining calcium deposits.
5. If necessary, repeat the decalcification.
6. Open the cooking zone door and leave it open with a slight gap until the unit is used again.
 - ↳ This extends the service life of the door seal.
 - ↳ No moisture builds up in the cooking zone.

5.9 Cleaning the cooking zone automatically with WaveClean



CAUTION
Risk of chemical burns

Keep the cooking zone door closed during the cleaning procedure.



The use of unsuitable cleaning agents often causes damage to units. MKN makes great efforts to be able to offer a cleaning agent, which on the one hand achieves an outstanding cleaning performance, but which on the other hand does not attack and damage the convection steamer. We therefore recommend that only our cleaning agent is used. MKN does not assume any responsibility or liability for damage, which is caused by unsuitable cleaning agents. Claims against MKN that are due to this can not be upheld, not even within the scope of the guarantee or warranty.



It is not permitted to cool the temperature sensor down in order to start the cleaning procedure more quickly. The whole cooking zone must be cooled down to 60 °C for effective cleaning.



Depending on the cleaning level selected, the fan may be idle for up to 60 minutes. This is not a cancellation of the cleaning but part of the cleaning program.



Automatic forced rinse is triggered in the following situations.

- Cleaning is cancelled manually. Cancelling within the first 10 minutes of cleaning does not trigger an automatic forced rinse.
- Cleaning is cancelled automatically in the event of a fault.
- The Combisteamer is switched off and then back on during cleaning. The automatic forced rinse begins when the unit is switched back on.



If the automatic forced rinse is cancelled, it starts again from the beginning.

It is not possible to start a cooking program, before the forced rinse is ended.

5.9.1 Preparing for cleaning

ATTENTION

Risk of physical damage from improper cleaning

- Do not clean the unit with a high-pressure cleaner or water jet.

Requirement GN containers, baking trays and grates removed from the cooking zone

1. Remove any food remains from the cooking zone.
↳ The drain screen is not obstructed.
2. Leave only the support rack in the cooking zone in countertop units, and leave only the tray trolley in the cooking zone in floor-standing units.
3. Close the cooking zone door.

5.9.2 Selecting the cleaning level



Despite different cleaning times, all cleaning levels required the same amount of water.

Tip

In the case of automatic cleaning overnight, we recommend the "medium" or "intensive" cleaning level. This ensures that there is sufficient drying.

Requirement Unit switched on
Main menu is displayed

1. Press the "WaveClean" button
2. Select the cleaning level.
↳ *Operating instructions* window is displayed.

3. Tap the *Confirm* button.
 - ↳ The *Cleaning level selection* window is displayed.
4. Tap the "Start Stop" button.
 - ↳ If necessary, the cooking zone is cooled down until the cleaning temperature of 60 °C is reached.

5.9.3 Inserting the cleaning cartridge



Use only cleaning cartridges with an undamaged wax seal.

If the wax seal is damaged, the cleaner can enter the cleaning circuit prematurely or not dissolve completely, so that complete cleaning is no longer assured.

Insert the cleaning cartridges only when requested to do so.



Never operate the unit in the automatic cleaning mode without a cleaning cartridge.

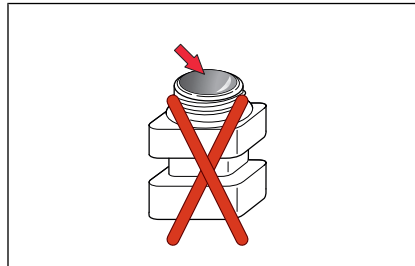

Image: Wax seal on the cleaning cartridge damaged

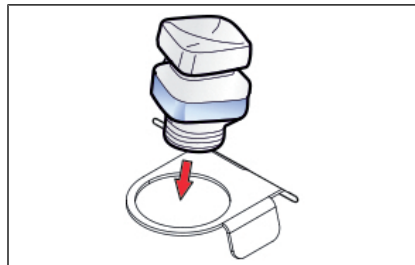

Image: Insert the cleaning cartridge in the holder

Requirements Cleaning cartridge sealed and undamaged

1. Open the cooking zone door.
2. Open the lid of the cleaning cartridge.
3. Insert the cleaning cartridge into the holder on the air diverter.
4. Close the cooking zone door.

5.9.4 Starting automatic cleaning



Never operate the unit in the automatic cleaning mode without a cleaning cartridge.

- Requirements**
- Water connection is open
 - The unit is on
 - Cleaning level selected
 - Cleaning cartridge inserted
 - Cooking zone temperature at 60 °C

→ Tap the "START STOPP" button.

↳ The display shows the remaining time.

5.9.5 Cancelling automatic cleaning

1. Tap the "STOPP" button.
 - ↳ Automatic cleaning is cancelled.
 - ↳ Automatic rinsing starts and cannot be cancelled.
 - ↳ Upon completion, a prompt appears to remove the cleaning cartridge.
2. Remove the cleaning cartridge.

5.9.6 Ending automatic cleaning



CAUTION
Risk of chemical burns

Droplet quantities can contain caustic constituents, so suitable protective measures must be taken.

Requirement Automatic rinsing has stopped after the cleaning program was cancelled or the cleaning time has elapsed

1. Open cooking zone door.
2. Remove the empty cleaning cartridge.
3. Use the hand shower to thoroughly rinse out any remaining cleaner or rinsing agent.
4. Close cooking zone door.
 - ↳ After the cooking zone door is closed, the cleaning program is completed.
5. Flush away any droplets of cleaning water on the floor in front of the unit with a soft water jet.
6. Open the cooking zone door and leave it open with a slight gap until the unit is used again.
 - ↳ This extends the service life of the door seal.
 - ↳ No moisture builds up in the cooking zone.

5.10 Cleaning the cooking zone manually

5.10.1 Preparing the cooking zone

ATTENTION

Risk of physical damage from improper cleaning

- Do not clean the unit with a high-pressure cleaner or water jet.
-

Requirement GN containers, baking sheets and grates removed from the cooking zone

1. Remove any food remains from the cooking zone.
↳ The drain screen is not obstructed.
2. Leave only the support rack in the cooking zone.
3. Close the cooking zone door.

5.10.2 Starting the cleaning program

Requirement The unit is switched on

→ Tap Manual cleaning.

5.10.3 Spraying the cleaner



CAUTION

Dangerous situation

Failure to observe precautions can result in slight to moderately severe injuries.

- Wear protective clothing.
 - Wear breathing protection.
-

ATTENTION

Risk of physical damage from exceeding the recommended acting time of the cleaner

- Do not allow the cleaner to act longer than specified by the program.
-

1. The menu field displays the instruction "Spray cleaner"
2. Put on protective clothing, safety goggles and protective gloves
3. Open cooking zone door.
4. Spray the cooking zone, heat register and fan wheel with cleaner.

5.10.4 Allowing the cleaner to act

- Close the cooking zone door.
 - ↳ The acting time starts.
 - ↳ The display shows the remaining time until the "Flush cooking zone" stage.

5.10.5 Starting cleaning

- The acting time has elapsed, the cleaning process starts automatically.
 - ↳ The cooking zone is heated.
 - ↳ The display shows the remaining time.

5.10.6 Drying the cooking zone

Requirement Cooking his own door closed

1. The drying process starts automatically.



The cooking zone is heated.

2. After the end of the drying process, a signal sounds.
 - ↳ "End" appears on the display.
3. Open the cooking zone door and leave it ajar until the unit is used again.
 - ↳ This extends the service life of the door seal.
 - ↳ No moisture builds up in the cooking zone.

5.11 Inspecting the unit

5.11.1 Performing a visual inspection

ATTENTION

Risk of physical damage from improper inspection

- Inspect in accordance with the inspection intervals.
 - Has inspection performed by a proficient operator.
 - In the event of damage or signs of wear, contact Customer service immediately and do not operate the unit any longer.
-

Requirement Unit disconnected from power
 Unit empty and cleaned
 Cooking zone door opened completely

- Inspect housing, cooking zone door and cooking zone yearly for deformation and damage.
 - ↳ Visual inspection has been performed.

6 Troubleshooting

6.1 Emergency mode

In order to allow limited use in case of error, the unit has several different emergency programs. Emergency operation is activated automatically and displayed. After elimination of the error indicated, the controls switch back into normal operation automatically. A reset is not necessary.



Emergency programs handle the limited further operation of the appliance until servicing. Deviating cooking results and temperature deviations are possible.

6.2 Nameplate

When contacting Customer service, please always provide the following data from the nameplate:

Serial number (SN)	
Type number (TYP)	

6.2.1 Explaining nameplate information

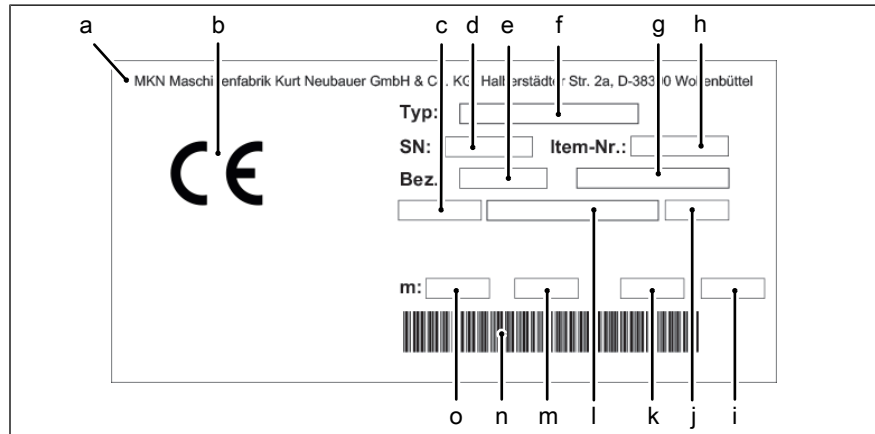

Image: Nameplate information

- a Manufacturer
- b CE mark
- c Electrical connected load
- d Serial number
- e Equipment abbreviation
- f Type number
- g Equipment designation
- h Item number
- i Frequency
- j Barcode
- k Country of destination
- l Type of connection
- m Protection class
- n Barcode
- o Weight



6.3 Causes of errors and remedies

If a fault occurs during operation, the error number and error message are displayed.

Fault no.	Error message displayed	Description	Measure to be taken
694 695	<ul style="list-style-type: none"> Cooking zone sensor is defective 	The internal core temperature sensor takes over the function of the defective cooking zone sensor.	<ul style="list-style-type: none"> Insert the internal core temperature sensor into its holder. A different cooking result may occur. Contact Customer service.
699 700 714 716	<ul style="list-style-type: none"> Internal core temperature sensor is defective 	The internal core temperature sensor in the cooking zone is deactivated.	<ul style="list-style-type: none"> If possible, use the external core temperature sensor (optional). Select another cooking program. Contact Customer service.
710	<ul style="list-style-type: none"> Vapour sensor defective 	Vapour elimination is now only controlled by the software. This results in higher water consumption.	<ul style="list-style-type: none"> Contact Customer service
	<ul style="list-style-type: none"> Water pressure too low 	As permanent error message	<ul style="list-style-type: none"> Open the water valve If the water valve is not closed, contact Customer service
	<ul style="list-style-type: none"> Water pressure too low 	As sporadic error message	<ul style="list-style-type: none"> Activate fewer simultaneous water consumers in the kitchen. Contact Customer service
	<ul style="list-style-type: none"> No water in the waste trap 	The waste trap is not filled with sufficient water.	<ul style="list-style-type: none"> Open the water valve 2 Pour water into the cooking zone If the error message persists, contact Customer service
	<ul style="list-style-type: none"> Unit restarted after a power failure 	If there was no power failure in the kitchen, it could be an operating error. An example of this would be unintentional switching on and off during a running cooking program.	<ul style="list-style-type: none"> Power failure < 1 minute Confirm the power failure message Continue with the cooking program No cleaning necessary Power failure > 1 minute Cooking program cancelled Perform cleaning
	<ul style="list-style-type: none"> WaveClean cancelled 	<ul style="list-style-type: none"> Please observe the explanations and notes in the chapter on "Automatic cleaning (WaveClean)" 	

7 Carrying out maintenance

The manufacturer recommends professional maintenance of the unit by trained technical personnel at maintenance intervals of 12 months. With heavier use, a maintenance interval of 6 months is recommended.

8 Dispose of unit in an environmentally responsible manner

The unit has been designed to provide a lifetime of 10 years with average use.

Do not dispose of unit or the unit's components together with non-recyclable waste. If the unit is disposed of together with non-recyclable waste or treated improperly, toxic substances contained in the unit can damage health and pollute the environment.

Dispose of the unit in accordance with local regulations for used appliances. Clarify any open questions with the responsible agencies (for instance, solid waste management).

We are a registered manufacturer at the **elektro-altgeräte** register foundation, and we are listed in the **ear** directory. If required, please contact one of the foundation's disposal agents. (WEEE-Reg.-Nr.DE 19459438)

Unit In addition to valuable materials, used electrical and electronic equipment also contains harmful substances that were needed for their operation and safety.

Cleaning agents Dispose of leftover cleaning agents and cleaning agent containers in accordance with the information provided by the cleaning agent's manufacturer. Observe applicable regional regulations.

Residues from cooking Residues from cooking and food must be collected in suitable containers and disposed of in accordance with the regionally applicable regulations.

9 Manufacturer's declaration



EC Declaration of Conformity



Manufacturer

MKN Maschinenfabrik Kurt Neubauer GmbH & Co. KG • Halberstädter Straße 2a • 38300 Wolfenbüttel, Germany

We hereby declare, that the following product:

Description of the unit	
Unit for cooking food in commercial applications	
Designation	
Compact Magic Team electric combi-steamer	
Type number	
TKECOD610XXXX	
X: Equipment feature	

complies with the relevant provisions of the following directives and regulations, but does not contain any assurance of properties:

- Directive 2006/42/EC dated 17 May 2006 on machinery
- Directive 2011/65/EU (RoHS) dated 01 July 2011
- Directive 2014/30/EU dated 26 February 2014 on electromagnetic compatibility
- REGULATION (EC) No. 1935/2004 dated 27 October 2004 on materials and objects, which are intended to come into contact with food

Adduced basis for verification
EN ISO 12100:2010
EN 60335-1:2002 + A11:2004 + A1:2004 + A12:2006 + A2:2006 + A13:2008 + A14:2010 + A15:2012
DIN EN 55014-1:2006
EN 55014-2:1997 + Corrigendum 1997 + A1:2001 + A2:2008
EN 60335-2-42:2003 + A1:2008
EN 60335-1:2012+A11:2014

The manufacturer bears the sole responsibility for issuing this Declaration of Conformity. This Declaration of Conformity becomes invalid, if changes are made which are not agreed with us.

Translation from the original document • 4127001--0KODE-A

Wolfenbüttel, 18/12/2018

Person authorised to compile the technical documents:

ppa. Peter Helm, Chief Technical Officer (address as manufacturer)





Declaration of Conformity



Manufacturer

MKN Maschinenfabrik Kurt Neubauer GmbH & Co. KG • Halberstädter Straße 2a • 38300 Wolfenbüttel, Germany

We hereby declare, that the following product:

Description of the unit	
Unit for cooking food in commercial applications	
Designation	
Compact Magic Team electric combisteamer	
Type number	
TKECOD610XXX	
X: Equipment feature	

complies with the relevant provisions of the following directives and regulations, but does not contain any assurance of properties:

- Directive 2006/42/EC dated 17 May 2006 on machinery
- Directive 2011/65/EU (RoHS) dated 01 July 2011
- Electromagnetic Compatibility Regulations 2016
- REGULATION (EC) No. 1935/2004 dated 27 October 2004 on materials and objects, which are intended to come into contact with food

Added basis for verification
EN ISO 12100:2010
EN 60335-1:2002 + A11:2004 + A1:2004 + A12:2006 + A2:2006 + A13:2008 + A14:2010 + A15:2012
BS EN 55014-1 + A11:2017-05
EN 55014-2:1997 + Corrigendum 1997 + A1:2001 + A2:2008
EN 60335-2-42:2003 + A1:2008
EN 60335-1:2012+A11:2014

The manufacturer bears the sole responsibility for issuing this Declaration of Conformity. This Declaration of Conformity becomes invalid, if changes are made which are not agreed with us.

Wolfenbüttel, 15/11/2022

Person authorised to compile the technical documents:

ppa. Peter Helm, Chief Technical Officer (address as manufacturer)





Declaration of Conformity



Manufacturer

MKN Maschinenfabrik Kurt Neubauer GmbH & Co. KG • Halberstädter Straße 2a • 38300 Wolfenbüttel, Germany

We hereby declare, that the following product:

Description of the unit	
Unit for cooking food in commercial applications	
Designation	
Compact Magic Team electric combisteamer	
Type number	
TKECOD610XXXX	
X: Equipment feature	

complies with the relevant provisions of the following directives and regulations, but does not contain any assurance of properties:

- Directive 2006/42/EC dated 17 May 2006 on machinery
- Directive 2011/65/EU (RoHS) dated 01 July 2011
- Electromagnetic Compatibility Regulations 2016
- REGULATION (EC) No. 1935/2004 dated 27 October 2004 on materials and objects, which are intended to come into contact with food

Adduced basis for verification
EN ISO 12100:2010
EN 60335-1:2002 + A11:2004 + A1:2004 + A12:2006 + A2:2006 + A13:2008 + A14:2010 + A15:2012
BS EN 55014-1 + A11:2017-05
EN 55014-2:1997 + Corrigendum 1997 + A1:2001 + A2:2008
EN 60335-2-42:2003 + A1:2008
EN 60335-1:2012+A11:2014

The manufacturer bears the sole responsibility for issuing this Declaration of Conformity. This Declaration of Conformity becomes invalid, if changes are made which are not agreed with us.

Wolfenbüttel, 15/11/2022

Person authorised to compile the technical documents:

ppa. Peter Helm, Chief Technical Officer (address as manufacturer)



A		L	
After-cooking	20	Low-temperature cooking	18
Automatic cooking (autoChef)		M	
Cooking program, modifying	74	Main menu	22, 28
Delete Cooking program	75	Manual cooking	63
Export Cooking program	75	Create and save Cooking program	66
Find and open cooking program	72	Create Cooking program step	63
Import Cooking program	77	Export Cooking program	71
Automatic forced rinse	85	O	
C		Operation locked	33
Change basic settings	29	P	
ChefsHelp	20	PerfectHOLD	19
Cleaning		Q	
Automatic cleaning (WaveClean)	85	QualityControl	20
Cleaning cartridge (WaveClean)	86	R	
Lock touchscreen	82	RackControl	20
Manual cleaning	88	Ready2Cook	19
ClimaSelect plus	21	Recipes	
Combisteamng	18	Import recipes	38
Convection	18	Regenerate	18
Core temperature measurement		Resting time	20
4-point core temperature sensor		S	
measurement	61	SES	19
Set core temperature	43	Set cooking time	40
Standard setting value	24	Set fan	44
Core temperature sensor		Set favourites	33
Core temperature measurement	21	Settings	
D		Set date and time	31
Delta-T cooking	18	Start-time preselection	19
DynaSteam ²	21	Steaming	18
E		T	
Environmentally friendly disposal	93	Temperature	
Equipment information, calling up	31	Cooking temperature, setting	39
F		Standard setting value	24
FamilyMix	20	Time2Serve	21
H		V	
HACCP	60	Video	
Humidification		Import video	37
Manual	20	Video, deleting	78
I			
Images			
Importing images	37		

www.mkn.com

