

avintage

Built-under range

2-compartments service wine cabinet

17 bottles*

AVU18CDZA

- *Built-under counter installation*
- *Cooling system: compressor (air moving system)*
- *Adjustable temperature range of use:
10°-20°C/5°-10°C*
- *Black metal external body*
- *Black PVC inner liner*
- *1 reversible glass door, anti-UV treated, 2-layers
tempered glass (brown colored), black piano
organic glass frame*
- *Electronic regulation*
- *2 semi-sliding metal shelves, wooden front*
1 semi-sliding metal half shelf, wooden front

*An Avintage innovation!
New elegant design and optimization of energy
consumption: **A class.***

*Thanks to **temperature alarms**, offer the best
protection to your bottles of wine.*



avintage

Reference: AVU18CDZA

- **Ambient temperature range of use:**
0°-38°C
- **Equipments included:**
4 adjustable feet (height 6.5 cm)
Plumbing passage
White LED lights with ON/OFF switch button
Anti-vibration system
Removable aeration system
Winter system
Water tray to maintain proper hygrometry
Thermometer with electronic display (white)
- **Technical characteristics:**
Voltage: 220-240 V
Power input: 74.0 W
Annual electrical consumption: 138.0 kWh
Energy class: A
Climatic class: N-ST
Noise level: 43.0 dB

- **Logistic datas:**

Dimension UVC (W x D x H cm):

Packed: 34 x 63 x 85
Unpacked: 29.5 x 57.3 x 82

Weight UVC (Kg):

Gross: 34,00
Net: 32,00

Pallet dimensions (cm): 0

Full truck (UVC): 252

Container (UVC):

20': 146
40': 294
40' HC: 366

Gencod UVC: 3595320105285

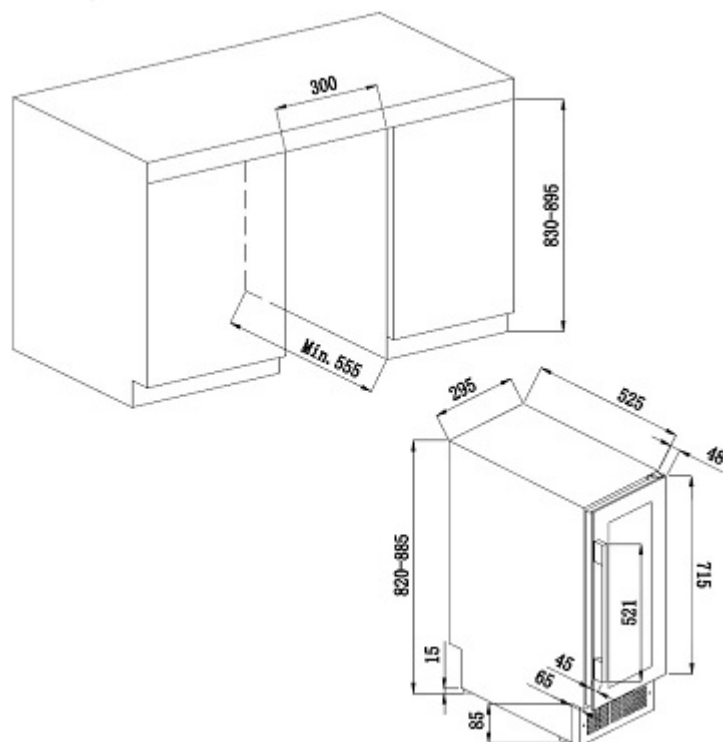

Non-contractual pictures

* Capacity given with 75cl Bordeaux traditional type bottles on 3 shelves. Adding shelves reduce considerably the total capacity.